

CUSTOMER :

**SPECIFICATIONS**  
**FOR PURE GREEN CHIP LED**

**Model : OPG-SM1608-04T**

Date : 2003. 10.



Tel : 82-42-931-9114 Fax : 82-42-931-0980

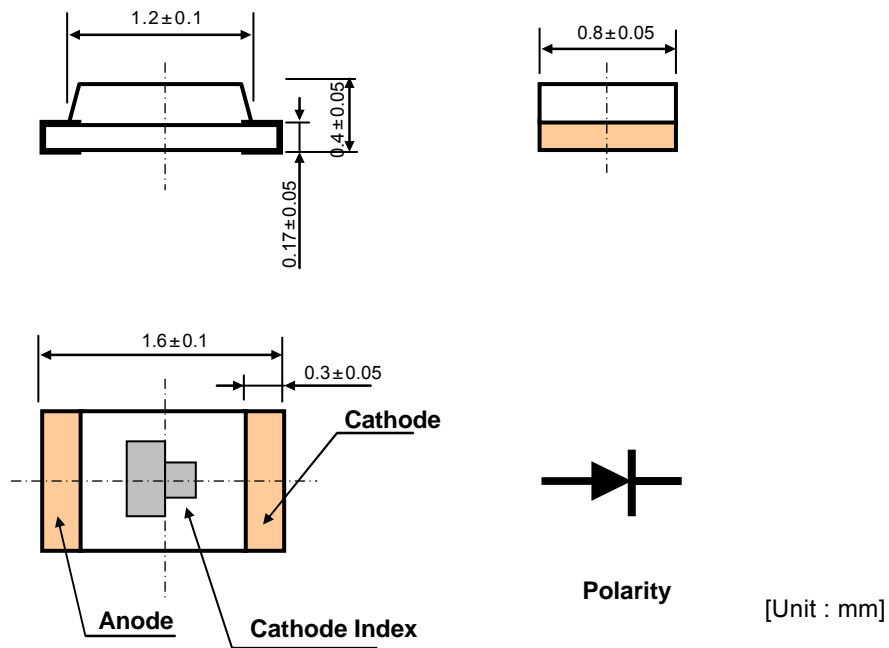
1683-2, Sinil-dong, Daeduck-gu, Daejeon 306-230, Korea

<http://www.optoway.com>, email : [optoway@optoway.com](mailto:optoway@optoway.com)

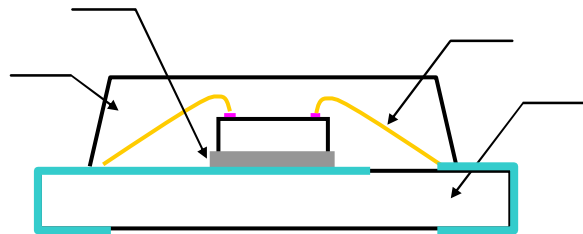
## **Contents**

1. Dimensions
2. Features
3. Applications
4. Absolute Maximum Rates
5. Electro-Optical Characteristics
6. Rank
7. Characteristic Diagrams
8. Recommended Soldering Pattern
9. Reflow Soldering Profile
10. Manual Soldering Condition
11. Packing
12. Packing Structure
13. Lot Number
14. Caution For Use

## Dimensions



**Fig. 1 Outline Diagrams and Dimensions**



**Fig. 2 Component Name and Its Material**

No.	Item	Material
	PCB	BT Resine
	Paste	Ag
	Wire	Au
	Epoxy	Epoxy

## Features

- Transparent clear lens optic
- 1.6 × 0.8 × 0.4 (L×W×H) small size surface mount type
- Taping : 8mm tape with 4000/reel, Φ180mm

## Applications

- Mobile phone keypad and LCD backlight
- Symbol backlight
- Front panel indicator lamp

## Absolute Maximum Ratings

Item	Symbol	MIN	MAX	Unit	Test Condition
Forward Current	$I_F$		20	mA	
Forward Pulse Current <sup>(1)</sup>	$I_{FP}$		100	mA	
Power Dissipation	$P_O$		90	mW	
Reverse Voltage	$V_R$		5	V	
Operating Temperature	$T_{OP}$	-30	85		
Storage Temperature	$T_S$	-40	100		
Soldering Temperature	$T_{sol}$		260		5sec

(1) The condition of  $I_{FP}$  is duty 1/10, pulse width 50ms

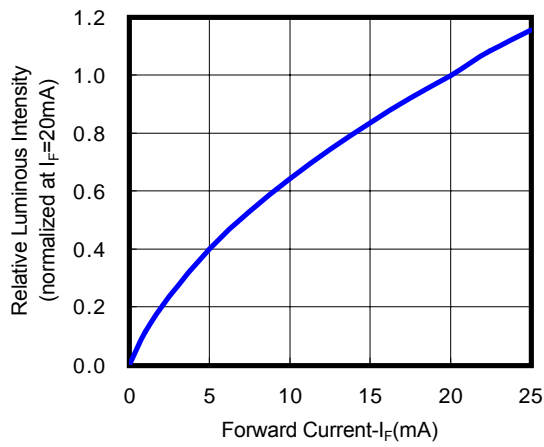
## Electro-Optical Characteristics ( at $T_A = 25^\circ\text{C}$ )

Item	Symbol	MIN	TYP	MAX	Unit	Test Condition
Forward Current	$V_F$	2.6	2.9	3.1	V	$I_F = 5\text{mA}$
Reverse Current	$I_R$	-	-	10	$\mu\text{A}$	$V_R = 5\text{V}$
Luminous Intensity	$I_V$	60	95	140	mcd	$I_F = 5\text{mA}$
Dominant Wavelength	$W_D$	527	530	537	nm	$I_F = 5\text{mA}$

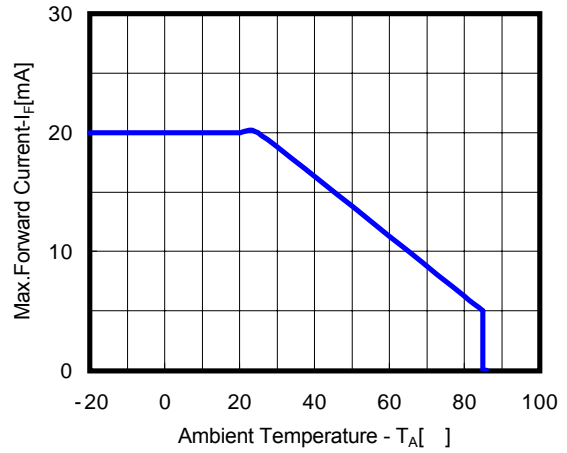
## Rank

Forward Voltage (@5mA)	Luminous Intensity (@5mA)	Dominant Wavelength(@5mA)	
		527~532nm	532~537nm
2.6~2.9 V	60~100 mcd	CR1	CS1
	100~140 mcd	DR1	DS1
2.9~3.1V	60~100 mcd	CR2	CS2
	100~140 mcd	DR2	DS2

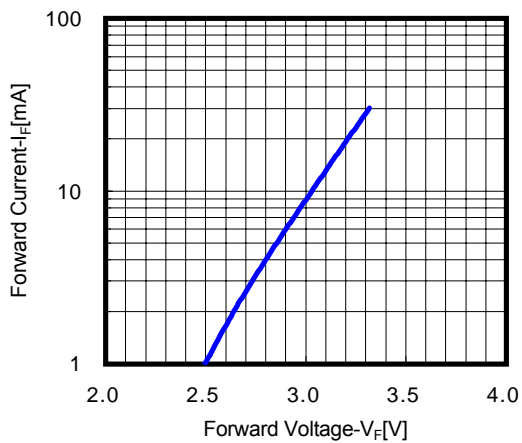
## Characteristic Diagrams



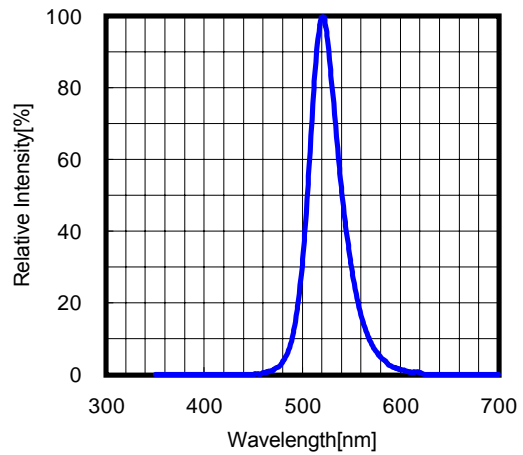
**Figure 3. Forward current vs. Relative Luminosity Intensity**



**Figure 4. Ambient Temperature vs. Max. Forward Current**

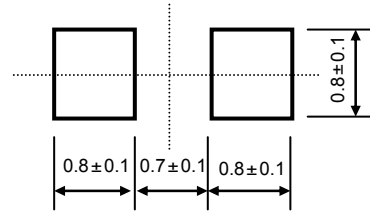


**Figure 5. Forward Voltage vs. Forward Current**



**Figure 6. Relative Intensity vs. Wavelength**

## Recommended Soldering Pattern



[Unit : mm]

Fig 7. Recommended Soldering Pattern

## Reflow Soldering Profile

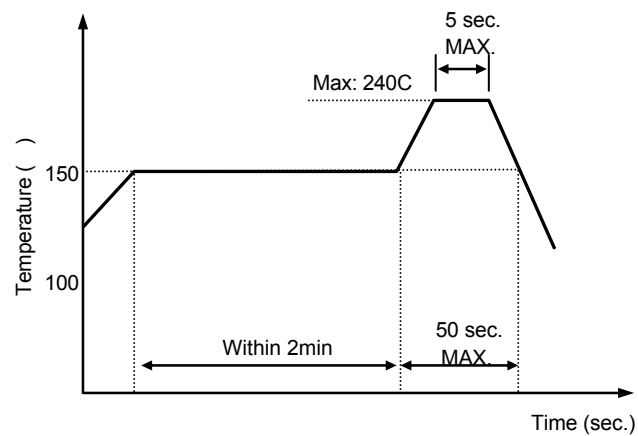
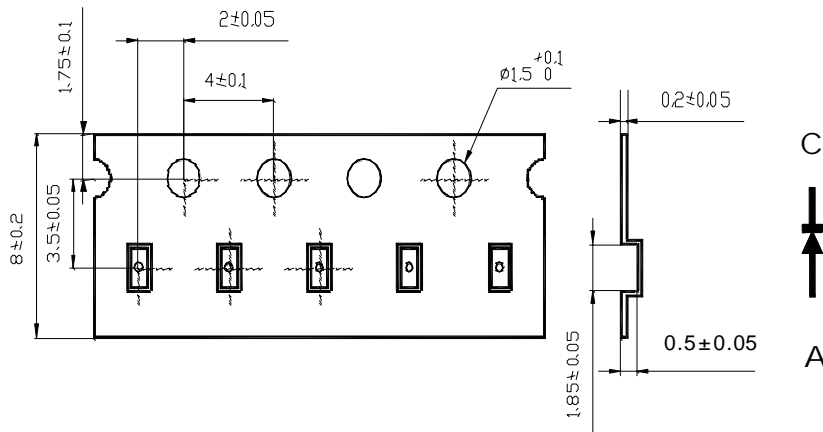


Fig 8. Recommended Reflow Soldering Profile

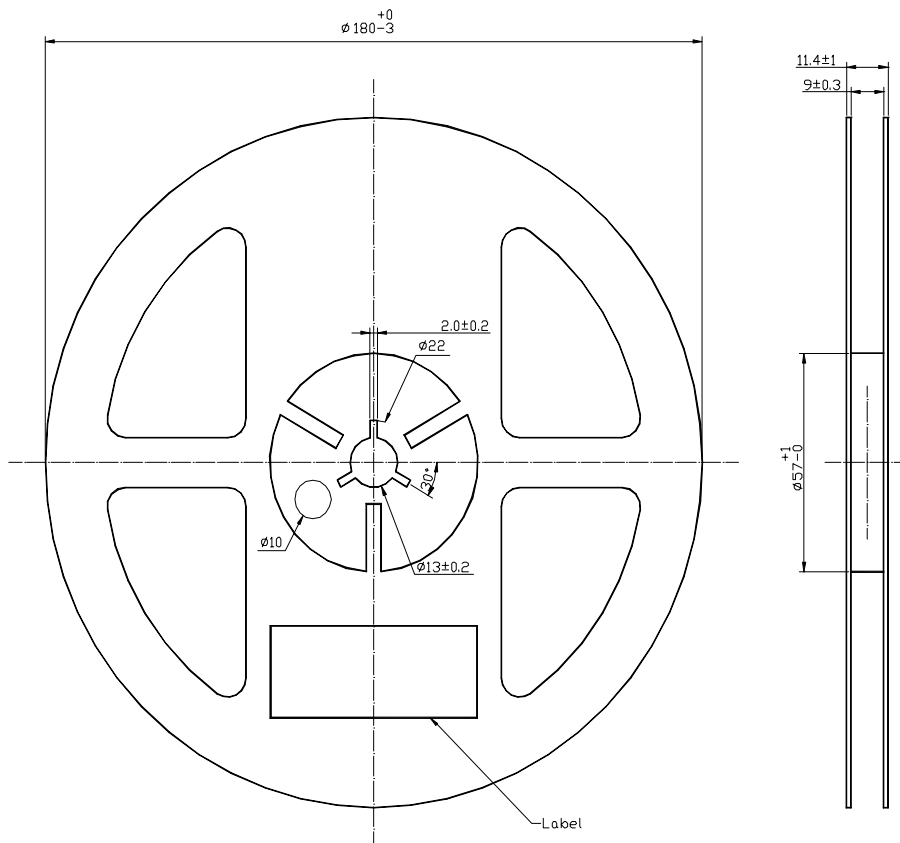
## Manual Soldering Condition

- When applying the manual soldering, it should not be more than 5 seconds @300 and a care must be taken to use the well grounded iron and not to put a stress during the soldering.

## Packing



**Fig 9. Tape-packing dimensions of Green Chip LEDs**

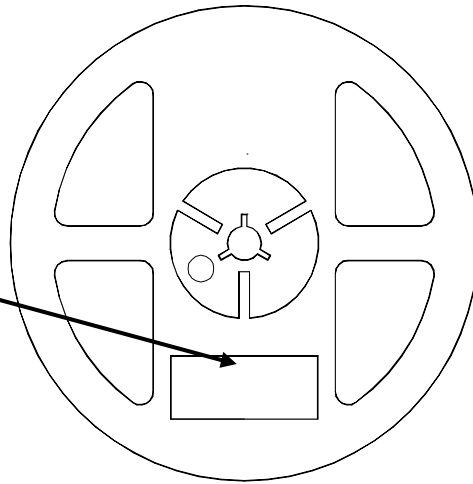
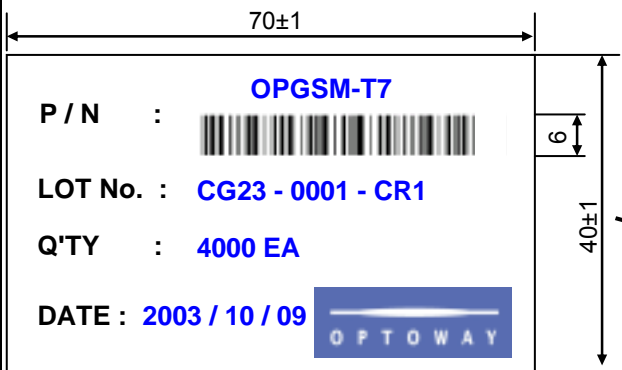


**Fig 10. Schematic diagram and their dimensions of the reel and tape for Green Chip LEDs**

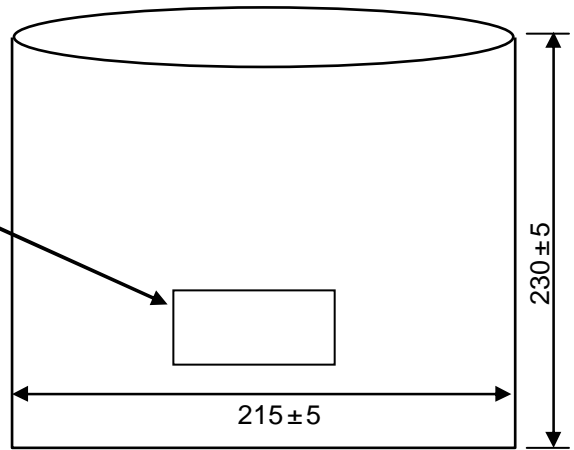
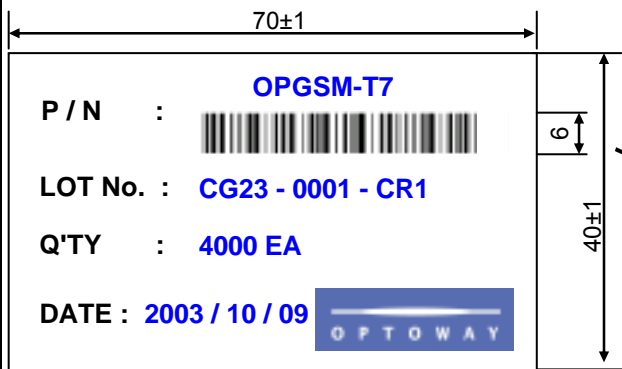
- (1) Quantity : The maximum packing quantity per one reel is to be 4000 pcs.
- (2) Adhesion strength of cover tape : adhesion strength to be 0.1-0.7N when the cover tape is taken off by 45° direction from the carrier tape.
- (3) Packaging : Serial no., manufacturing lot code and quantity are indicated on a damp proof label.
- (4) Carrier tape, reel and moisture barrier bag are protected from an electro-static discharge(ESD).

## Packing Structure

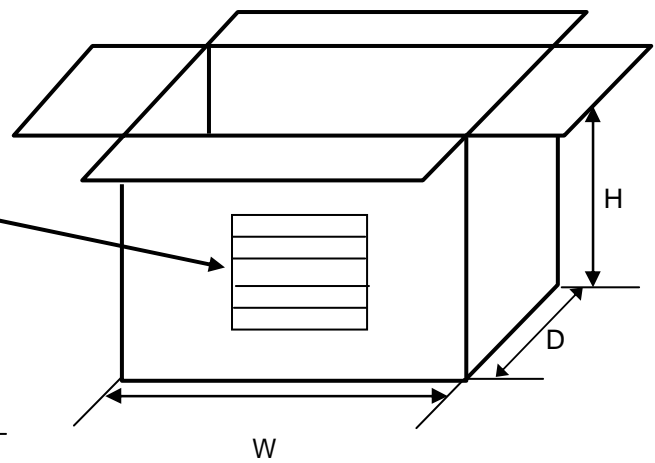
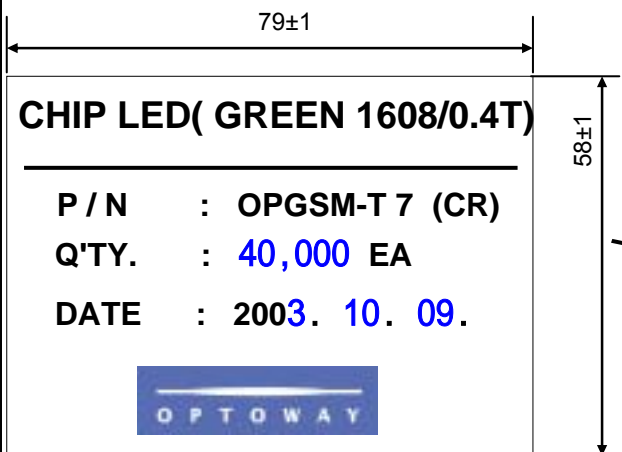
### Reel



### Al shielding Bag



### Inner Box Structure



Material : Cardboard Paper (brown color)

Size(mm) : W x D x H = 240 x 220 x 140

[Unit : mm]

