

SPS-2310VMW-CXXG / SPS-2310AVMW-CXXG

(RoHS Compliant)

12 Gb/s / 10 km / CWDM Medium Power Single Optical SM Digital Diagnostic Transmitter

FEATURES

- SMPTE 2082, SMPTE 424M, SMPTE 292M, SMPTE 259M, and DVB-ASI Compatible
- Speed up to 12 Gb/s
- Distance up to 10 km for 12G-SDI
- Reclocker built-in
- Support Video Pathological Patterns for HD-SDI, 3G-SDI, 6G-SDI, and 12G-SDI
- Single CWDM Transmitter: 1270 nm to 1610 nm
- Based on Industry Standard SFP +
- SFF-8472 Digital Diagnostic Function
- TTL Laser Disable Input
- Single +3.3 V Power Supply
- RoHS Compliant
- 0 to 70°C Operation: SPS-2310VMW-CXXG
- -40 to 85°C Operation: SPS-2310AVMW-CXXG
- Hot-Pluggable
- Class 1 Laser International Safety Standard IEC-60825 Compliant

DESCRIPTION

The SPS-2310VMW-CXXG series is a single channel single mode transmitter module designed to transmit optical serial digital signals as defined in SMPTE 2082, SMPTE 424M, SMPTE 292M, SMPTE 259M, and DVB-ASI. It supports up to 12Gbps and is specifically designed to transmit the pathological patterns for HD-SDI, 3G-SDI, 6G-SDI, and 12G-SDI. It is with the SFP+ 20-pin connector to allow hot plug capability. Digital diagnostic functions are available via an I²C. It uses a CWDM DFB lasers and is class 1 laser compliant according to International Safety Standard IEC-60825. A maximum distance of 10 km is achievable with 12Gbps pathological signals.

LASER SAFETY

This single mode transceiver is a Class 1 laser product. It complies with IEC-60825 and FDA 21 CFR 1040.10 and 1040.11. The transceiver must be operated within the specified temperature and voltage limits. The optical ports of the module shall be terminated with an optical connector or with a dust plug.

APPLICATIONS

- SMPTE 2082 Compliant Electrical-to-Optical Interfaces
- High-density Video Routers

ORDER INFORMATION

P/No.	Type	Bit Rate (Gb/s)	TX1		TX2		Package	Temp (°C)	RoHS Compliant
			λ (nm)	Power (dBm)	λ (nm)	Power (dBm)			
SPS-2310VMW-CXXG	1-TX	Up to 12	XX*	5 to 0			LC SFP+ with DMI	0 to 70	Yes
SPS-2310AVMW-CXXG	1-TX	Up to 12	XX*	5 to 0			LC SFP+ with DMI	-40 to 85	Yes

*: XX is for Channel 1 CWDM Wavelength (0 to 70°C)

Central Wavelength	Min. (nm)	Typ. (nm)	Max. (nm)	Clasp Color Code	Central Wavelength	Min. (nm)	Typ. (nm)	Max. (nm)	Clasp Color Code
-C27	1264.5	1270	1277.5	Light Purple	-C45	1444.5	1450	1457.5	Yellow Orange
-C29	1284.5	1290	1297.5	Sky Blue	-C47	1464.5	1470	1477.5	Gray
-C31	1304.5	1310	1317.5	Yellow Green	-C49	1484.5	1490	1497.5	Violet
-C33	1324.5	1330	1337.5	Yellow Ocher	-C51	1504.5	1510	1517.5	Blue
-C35	1344.5	1350	1357.5	Pink	-C53	1524.5	1530	1537.5	Green
-C37	1364.5	1370	1377.5	Beige	-C55	1544.5	1550	1557.5	Yellow
-C39	1384.5	1390	1397.5	White	-C57	1564.5	1570	1577.5	Orange
-C41	1404.5	1410	1417.5	Silver	-C59	1584.5	1590	1597.5	Red
-C43	1424.5	1430	1437.5	Black	-C61	1604.5	1610	1617.5	Brown

CWDM*: 18 Wavelengths from 1270 nm to 1610 nm, each step 20 nm.

Clasp Color Code**: Clasp Color Code is for Channel 1 CWDM Wavelength

RELATED PRODUCTS

P/No.	Type	Bit Rate (Gb/s)	RX1		RX2		Package	Temp (°C)	RoHS Compliant
			λ (nm)	Sen. (dBm)	λ (nm)	Sen. (dBm)			
SPS-2116VMW-IRG	1-RX	Up to 12	1260/1620	-1 to -11			LC SFP+ with DMI	0 to 70	Yes

Absolute Maximum Ratings					
Parameter	Symbol	Min	Max	Units	Notes
Storage Temperature	Tstg	-40	85	°C	
Operating Case Temperature	Topr	0	70	°C	SPS-2310VMW-CXXG
		-40	85		SPS-2310AVMW-CXXG
Power Supply Voltage	Vcc	-0.5	3.6	V	

Recommended Operating Conditions					
Parameter	Symbol	Min	Typ	Max	Units / Notes
Power Supply Voltage	Vcc	3.13	3.3	3.47	V
Operating Case Temperature	Topr	0		70	°C / SPS-2310VMW-CXXG
		-40		85	°C / SPS-2310AVMW-CXXG
Power Supply Current	Icc		280	300	mA / C270 – C570
			360	380	mA / C590, C610
			430	450	mA / SPS-2310AVMW-CXXG
Data Rate			11.88		Gb/s

Transmitter Optical Specifications (3.13V < Vcc < 3.47V)						
Parameter	Symbol	Min	Typ	Max	Units	Notes
Average Launch Power	PO, Avg	0		5	dBm	1
Output Center Wavelength	λ	$\lambda_c-5.5$	λ_c	$\lambda_c+7.5$	nm	2
Output Spectrum Width	σ_λ			1	nm	-20 dB width
Side Mode Suppression Ratio	SMSR	30			dB	
Extinction Ratio	ER	3.5				
Relative Intensity Noise	RIN			-128	dB/Hz	
Average Launch Power of OFF Transmitter				-30	dBm	

1. Output power is power coupled into a 9/125 μm single-mode fiber.
2. ITU-T G.694.2 CWDM wavelength from 1270 nm to 1610 nm, each step 20 nm.

Electrical Characteristics						
Parameter	Symbol	Min	Typ	Max	Units	Notes
High-Speed Signal (CML) Interface Specification						
Input Data Rate			11.88		Gb/s	
Differential Input Impedance	Rin		100		Ω	
Low-Speed Signal (LVTTTL) Interface Specification						
Input High Voltage		2.0		Vcc+0.3	V	
Input Low Voltage		GND		0.8	V	

CONNECTION DIAGRAM

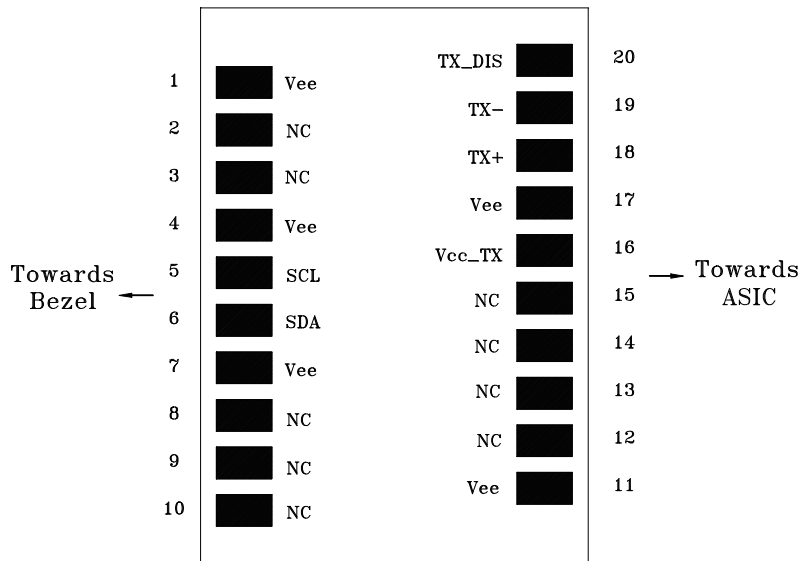

PIN	Name	Function	Notes
1	Vee	Signal Ground	
2	NC	No Connection	
3	NC	No Connection	
4	Vee	Signal Ground	
5	SCL	Serial I ² C Clock	
6	SDA	Serial I ² C Data	
7	Vee	Signal Ground	
8	NC	No Connection	
9	NC	No Connection	
10	NC	No Connection	
11	Vee	Signal Ground	
12	NC	No Connection	
13	NC	No Connection	
14	Vee	Signal Ground	
15	NC	No Connection	
16	Vcc TX	Power Supply	+3.3V±5%, Internal connected
17	Vee	Signal Ground	
18	TX+	Positive Transmitter Data In	AC coupled differential lines with 100 ohm differential termination inside the module
19	TX-	Negative Transmitter Data In	
20	TX_DIS	Transmitter Disable	Internal 4.7 kΩ pull-up. The bias current and modulation current are turned off if TX1_DIS = HIGH.

MODULE DEFINITION

Module Definition	PIN 5	PIN 6	Interpretation by Host
4	SCL	SDA	Serial module definition protocol

Module Definition 4 specifies a serial definition protocol. For this definition, upon power up, SCL and SDA appear as no connector (NC). When the host system detects this condition, it activates the serial protocol. The protocol uses the 2-wire serial CMOS E²PROM protocol of the ATMEL AT24C01A/02/04 family of components.

RECOMMENDED CIRCUIT SCHEMATIC

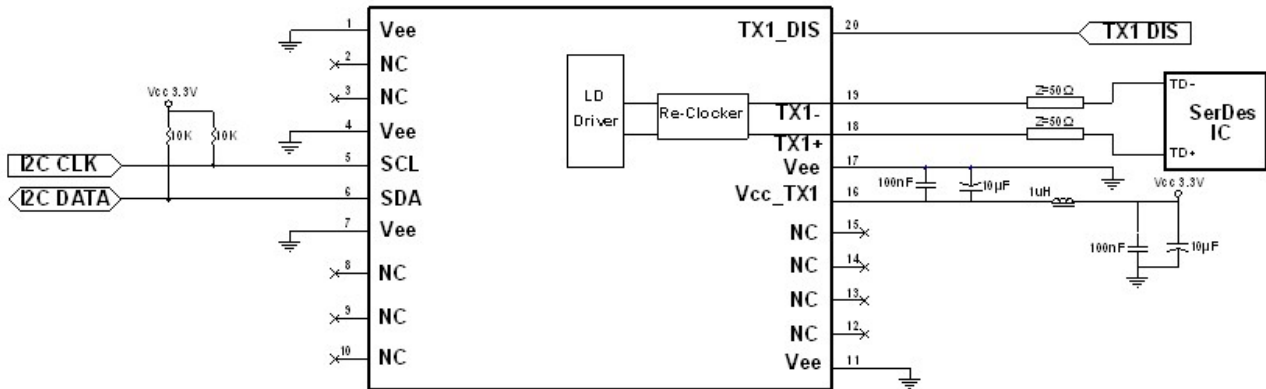

1. Consult the Chipset manufacturer's applications information for biasing required for TX outputs. Some chipset outputs are internally biased and may not need external bias resistor.

PACKAGE DIAGRAM

Units in mm

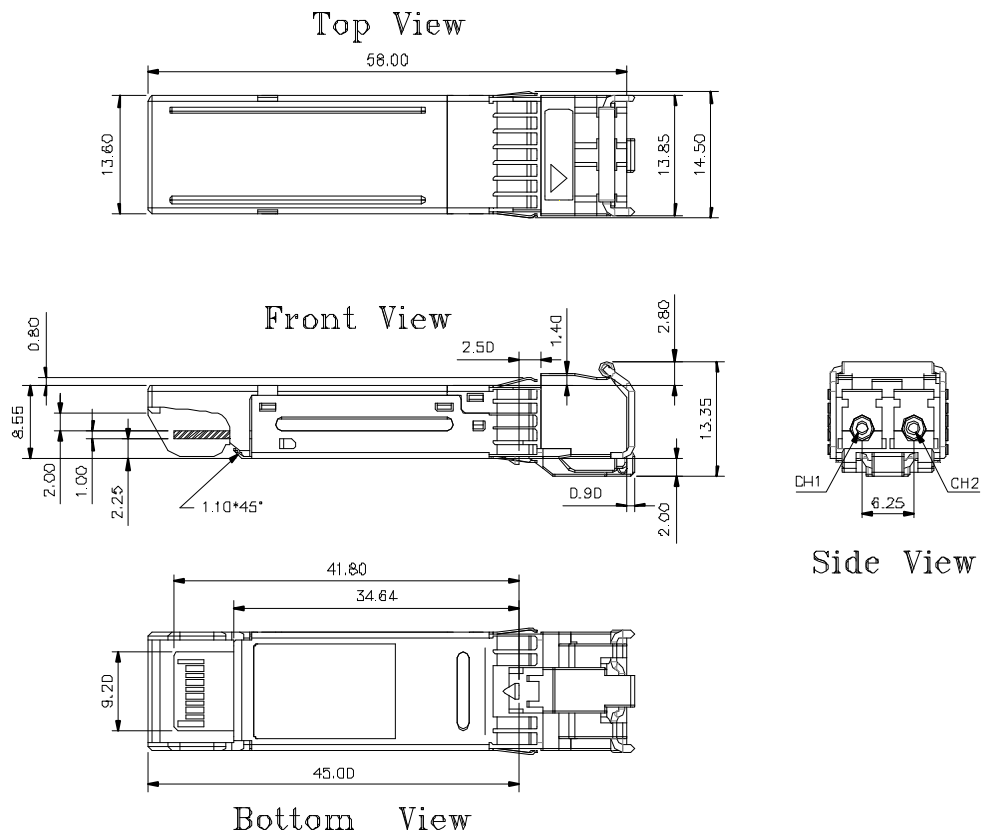

Note: Specifications subject to change without notice.

REVISION HISTORY

Version	Subject	Release Date
1.0	Initial datasheet	2023/2/16
2.0	Add I-Temp models	2023/9/12