TRS-53160G / TRS-53160TG / TRS-53160FG /
TRS-53160CG / TRS-53160CTG / TRS-53160CFG
3.3V / 1550 nm / 622 Mbps Optical Single-Mode Transceiver

(RoHS Compliant)

FEATURES

- Duplex SC Single Mode Transceiver: TRS-53160G
- Duplex ST Single Mode Transceiver: TRS-53160TG
- Duplex FC Single Mode Transceiver: TRS-53160FG
- Long-Reach SONET OC-12 / SDH STM-4 (L-4.2) Compliant
- 1550 nm DFB LD Transmitter
- Industry Standard 1 x 9 Footprint
- Single +3.3 V Power Supply
- Distance up to 160 km
- RoHS Compliant
- 0 to 70°C Operating: TRS-53160G
- -40 to 85°C Operating: TRS-53160AG
- PECL Signal Detection Output: TRS-53160G
- TTL Signal Detection Output: TRS-53160CG
- LED Multisourced 1 x 9 Transceiver Interchangeable
- Wave Solderable
- Class 1 Laser International Safety Standard IEC 60825 Compliant

DESCRIPTION

The TRS-53160G series single mode transceiver is a low power, high performance module for bi-directional serial optical data communications such as SONET OC-12 / SDH STM-4. This module is designed for single mode fiber and operates at a nominal wavelength of 1550 nm. The transmitter section uses a multiple quantum well 1550 nm DFB laser and is a class 1 laser compliant according to International Safety Standard IEC 60825. The receiver section uses an integrated InGaAs detector preamplifier (IDP) mounted in an optical header and a limiting post-amplifier IC. A PECL logic interface simplifies interface to external circuitry.

LASER SAFETY

This single mode transceiver is a Class 1 laser product. It complies with IEC 60825 and FDA 21 CFR 1040.10 and 1040.11. The transceiver must be operated within the specified temperature and voltage limits. The optical ports of the module shall be terminated with an optical connector or with a dust plug.

APPLICATIONS

- ATM 622 Mbps Links
- SONET / SDH Equipment Interconnect
- Fibre Channel 532 Mbps Links

ORDER INFORMATION

P/No.	Bit Rate (Mb/s)	SONET / SDH	Distance (km)	Wavelength (nm)	Voltage (V)	Package	Temp. (°C)	TX Power (dBm)	RX Sens. (dBm)	RoHS Compliant
TRS-53160G	622		160	1550 DFB	3.3	1X9 SC/ST/FC	0 to 70	5 to 0	-37	Y
TRS-53160AG	622		160	1550 DFB	3.3	1X9 SC/ST/FC	-40 to 85	5 to 0	-37	Y

Absolute Maximum Ratings					
Parameter	Symbol	Min	Max	Units	Notes
Storage Temperature	Tstg	-40	85	°C	
Operating Temperature	Topr	0	70	°C	TRS-53160G
		-40	85	°C	TRS-53160AG
Soldering Temperature	---		260	°C	10 seconds on leads only
Power Supply Voltage	Vcc	0	4.5	V	
Input Voltage	---	GND	Vcc	V	
Output Current	Iout	0	30	mA	

Recommended Operating Conditions					
Parameter	Symbol	Min	Typ	Max	Units
Power Supply Voltage	V _{cc}	3.1	3.3	3.5	V
Operating Temperature	T _{opr}	0		70	°C / TRS-53160G
		-40		85	°C / TRS-53160AG
Data Rate		50	622		Mb/s
Power Supply Current	I _{cc}			260	mA

Transmitter Specifications (0°C < T _{opr} < 70°C, 3.1V < V _{cc} < 3.5V)						
Parameter	Symbol	Min	Typ	Max	Units	Notes
Optical						
Optical Transmit Power	P _o	1	---	5	dBm	1
Output Center Wavelength	λ	1480	1550	1580	nm	
Output Spectrum Width	Δλ	---	---	1	nm	-20 dB Width
Side Mode Suppression Ratio	SMSR	30			dB	
Extinction Ratio	E _R	10	---	---	dB	
Output Eye	Compliant with Bellcore TR-NWT-000253 and ITU recommendation G.957					
Optical Rise Time	t _r			1.2	ns	10% to 90% Values
Optical Fall Time	t _f			1.2	ns	10% to 90% Values
Relative Intensity Noise	RIN			-116	dB/Hz	
Total Jitter	TJ			0.55	ns	2
Electrical						
Data Input Current – Low	I _{IL}	-350			μA	
Data Input Current – High	I _{IH}			350	μA	
Differential Input Voltage	V _{IH} - V _{IL}	300			mV	
Data Input Voltage – Low	V _{IL} - V _{CC}	-2.0		-1.58	V	3
Data Input Voltage -- High	V _{IH} - V _{CC}	-1.1		-0.74	V	3

- Notes: 1. Output power is power coupled into a 9/125 μm single mode fiber.
 2. Measured with a 2²³-1 PRBS with 72 ones and 72 zeros.
 3. These inputs are compatible with 10K, 10KH and 100K ECL and LVPECL inputs.

Receiver Specifications (0°C < T _{opr} < 70°C, 3.1V < V _{cc} < 3.5V)						
Parameter	Symbol	Min	Typ	Max	Units	Notes
Optical						
Sensitivity	---	---	---	-37	dBm	1
Maximum Input Power	P _{in}	-9		---	dBm	
Signal Detect -- Asserted	P _a	---	---	-37	dBm	Transition: low to high
Signal Detect -- Deasserted	P _d	-46	---	---	dBm	Transition: high to low
Signal detect -- Hysteresis		1.0	---		dB	
Wavelength of Operation		1100	---	1600	nm	
Electrical						
Data Output Voltage – Low	V _{OL} - V _{CC}	-2.0		-1.58	V	2
Data Output Voltage – High	V _{OH} - V _{CC}	-1.1		-0.74	V	2
Signal Detect Output Voltage -- Low	V _{OL} - V _{CC}	-2.0		-1.58	V	TRS-53160G
Signal Detect Output Voltage -- High	V _{OH} - V _{CC}	-1.1		-0.74	V	
Signal Detect Output Voltage -- Low	V _{SDL}			0.8	V	TRS-53160CG
Signal Detect Output Voltage -- High	V _{SDH}	2.0			V	

- Notes: 1. Minimum sensitivity and saturation levels at BER=1E-10 for a 2²³-1 PRBS with 72 ones and 72 zeros.
 2. These outputs are compatible with 10K, 10KH and 100K ECL and LVPECL outputs.

CONNECTION DIAGRAM

Receiver Signal Ground	1 (Rx GND)	○
Receiver Data Out	2 (RD+)	N/C
Receiver Data Out Bar	3 (RD-)	
Signal Detect	4 (SD)	
Receiver Power Supply	5 (Rx Vcc)	TOP VIEW
Transmitter Power Supply	6 (Tx Vcc)	
Transmitter Data In Bar	7 (TD-)	
Transmitter Data In	8 (TD+)	N/C
Transmitter Signal Ground	9 (Tx GND)	○

PIN	Symbol	Notes
1	Rx GND	Directly connect this pin to the receiver ground plane
2	RD+	See recommended circuit schematic
3	RD-	See recommended circuit schematic
4	SD	Active high on this indicates a received optical signal
5	Rx Vcc	+3.3V dc power for the receiver section
6	Tx Vcc	+3.3V dc power for the transmitter section
7	TD-	See recommended circuit schematic
8	TD+	See recommended circuit schematic
9	Tx GND	Directly connect this pin to the transmitter ground plane

RECOMMENDED CIRCUIT SCHEMATIC

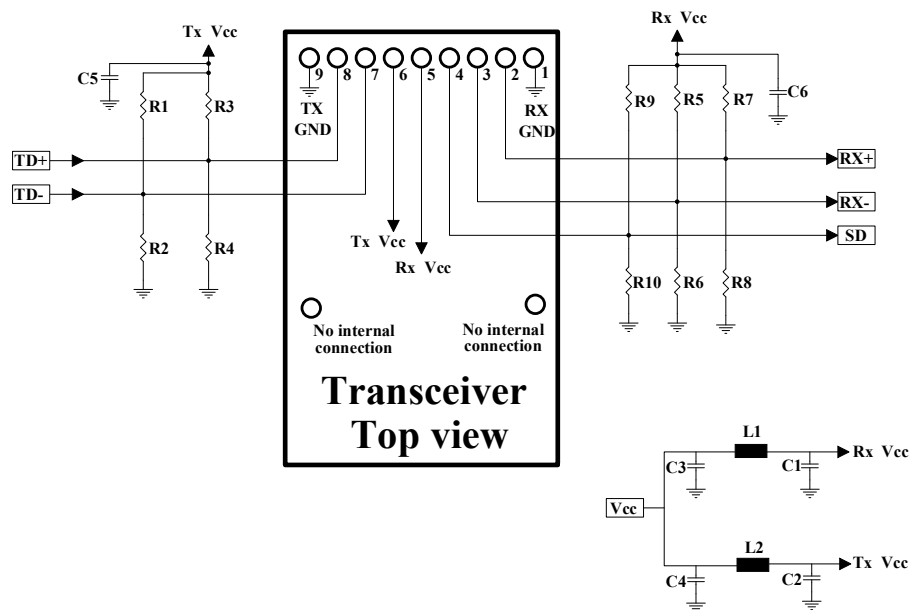

R1=R3=R5=R7=R9=130 ohm
R2=R4=R6=R8=R10=82 ohm
C1=C2=C3=C5=C6=0.1 uF
C4=10uF L1=L2=1uH

The split-load terminations for ECL signals need to be located at the input of devices receiving those ECL signals. The power supply filtering is required for good EMI performance. Use short tracks from the inductor L1/L2 to the module Rx Vcc and Tx Vcc. A GND plane under the module is required for good EMI and sensitivity performance.

PACKAGE DIAGRAM

Units in mm

1) SC Type

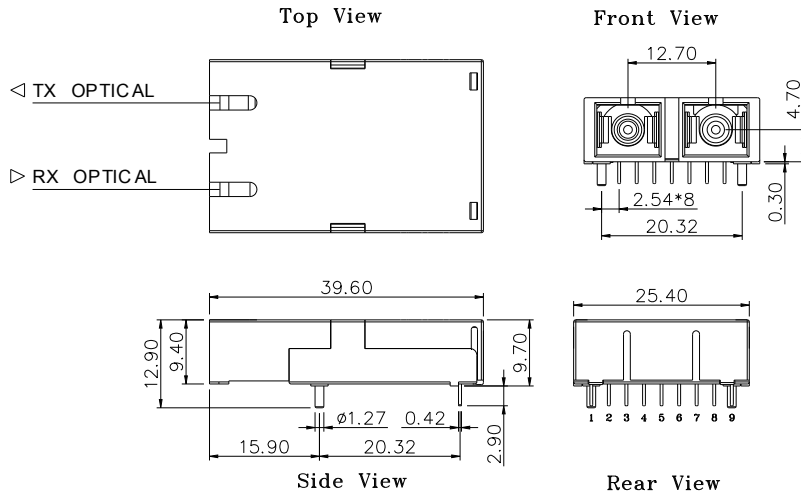

TRS-53160G / TRS-53160CG / TRS-53160AG / TRS-53160ACG

2) SC Type With Extended Shielding

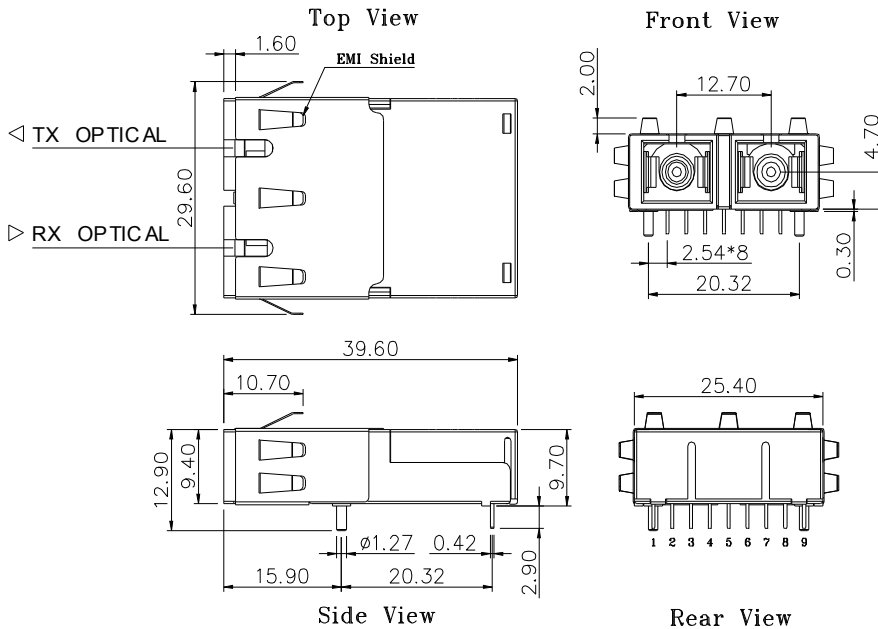

TRS-53160-EMG / TRS-53160C-EMG / TRS-53160A-EMG / TRS-53160AC-EMG

3) ST Type

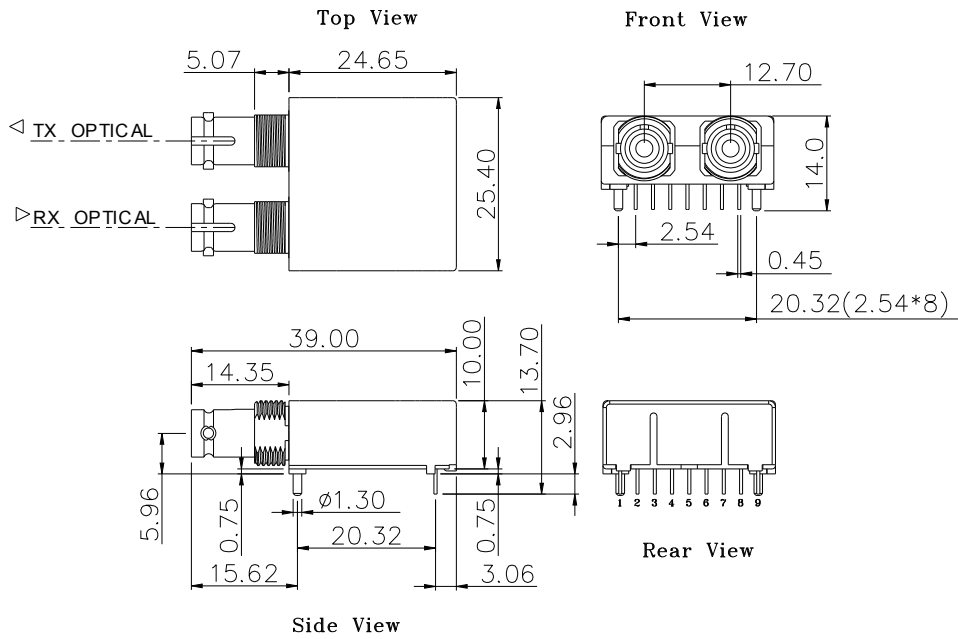

TRS-53160TG / TRS-53160CTG / TRS-53160ATG / TRS-53160ACTG

4) FC Type

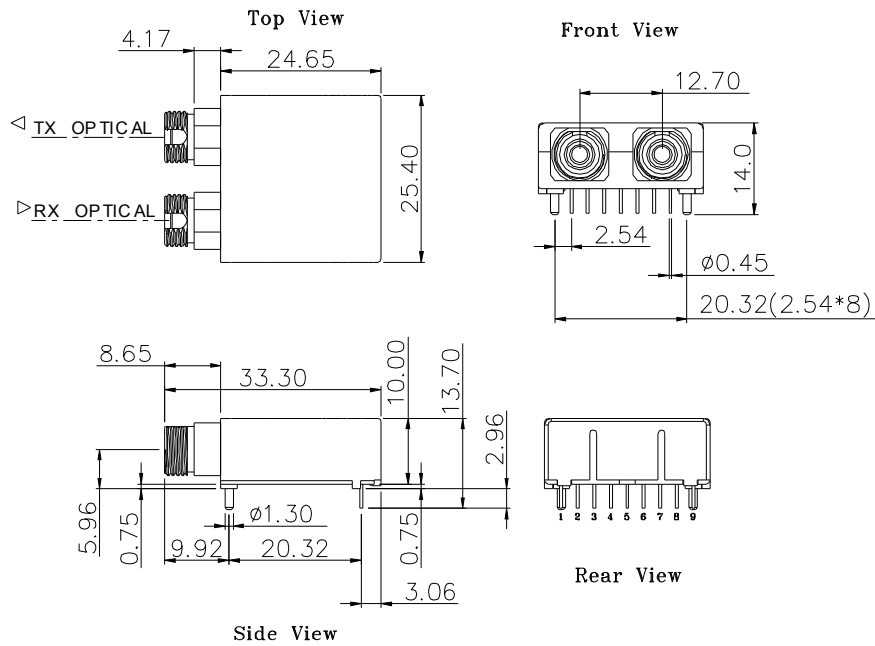

TRS-53160FG / TRS-53160CFG / TRS-53160AFG / TRS-53160ACFG

Note: Specifications subject to change without notice.

REVISION HISTORY

Version	Subject	Release Date
1.0	Initial datasheet	2008/1/1
2.0	Add -40 to 85°C version: TRS-53160AG	2025/3/26