

\*\*\*\*\*  
**TRS-7020G / TRS-7020TG / TRS-7020FG / TRS-7020CG / TRS-7020CTG / TRS-7020CFG**  
**5V / 1310 nm / 1.25 Gbps RoHS Compliant Optical Single-Mode Transceiver**  
 \*\*\*\*\*

### FEATURES

- Duplex SC Single Mode Transceiver: TRS-7020G
- Duplex ST Single Mode Transceiver: TRS-7020TG
- Duplex FC Single Mode Transceiver: TRS-7020FG
- Compliant with IEEE 802.3z Gigabit Ethernet
- Link Distance up to 20 km
- Link Power Budget at Least 16 dB
- Industry Standard 1 x 9 Footprint
- 0 to 70°C Operating: TRS-7020G
- -40 to 85°C Operating: TRS-7020AG
- Single +5 V Power Supply
- RoHS Compliant
- PECL Signal Detect Output: TRS-7020G
- TTL Signal Detect Output: TRS-7020CG
- Wave Solderable
- Class 1 Laser International Safety Standard IEC 60825 Compliant

### DESCRIPTION

The TRS-7020G series single mode transceiver is a low power, high performance module for bi-directional serial optical data communications such Gigabit Ethernet and Fibre Channel. This module is designed for single mode fiber and operates at a nominal wavelength of 1310 nm. The transmitter section uses a multiple quantum well laser and is a class 1 laser compliant according to International Safety Standard IEC 60825. The receiver section uses an integrated InGaAs detector preamplifier (IDP) mounted in an optical header and a limiting post-amplifier IC. A PECL logic interface simplifies interface to external circuitry.

### LASER SAFETY

This single mode transceiver is a Class 1 laser product. It complies with IEC 60825 and FDA 21 CFR 1040.10 and 1040.11. The transceiver must be operated within the specified temperature and voltage limits. The optical ports of the module shall be terminated with an optical connector or with a dust plug.

### APPLICATIONS

- Switch to Switch Interface
- High Speed Interface for File Servers
- High Performance Desktops

### ORDER INFORMATION

P/No.	Bit Rate (Mb/s)	1000 BASE	Distance (km)	Wavelength (nm)	Voltage (V)	Package	Temp. (°C)	TX Power (dBm)	RX Sens. (dBm)	RoHS Compliant
TRS-7020G	1250		20	1310	5	1X9 SC/ST/FC	0 to 70	-1 to -6	-22	Y
TRS-7020AG	1250		20	1310	5	1X9 SC/ST/FC	-40 to 85	-1 to -6	-22	Y

Note: TRS-XXXXXFG for FC duplex transceiver, TRS-XXXXXTG for ST duplex transceiver, TRS-XXXXX-EMG for SC duplex transceiver with extended EMI shielding, TRS-XXXXXCXG for transceiver with TTL signal detection output.

Absolute Maximum Ratings					
Parameter	Symbol	Min	Max	Units	Notes
Storage Temperature	Tstg	-40	85	°C	
Operating Temperature	Topr	0 -40	70 85	°C	TRS-7020G TRS-7020AG
Soldering Temperature	---		260	°C	10 seconds on leads only
Power Supply Voltage	Vcc	0	6	V	
Input Voltage	---	GND	Vcc	V	
Output Current	Iout	0	30	mA	

Recommended Operating Conditions					
Parameter	Symbol	Min	Typ	Max	Units
Power Supply Voltage	Vcc	4.75	5	5.25	V
Operating Temperature	Topr	0 -40		70 85	°C / TRS-7020G °C / TRS-7020AG
Data Rate			1250	1300	Mb/s
Power Supply Current	Icc			240	mA

Transmitter Specifications (0°C < Topr < 70°C, 4.75V < Vcc < 5.25V)						
Parameter	Symbol	Min	Typ	Max	Units	Notes
<b>Optical</b>						
Optical Transmit Power	Po	-6	---	-1	dBm	1
Output Center Wavelength	$\lambda$	1285	1310	1350	nm	
Output Spectrum Width	$\Delta\lambda$	---	---	2.0	nm	RMS( $\sigma$ )
Extinction Ratio	ER	9	---	---	dB	
Output Eye	Compliant with IEEE 802.3z					
Optical Rise Time	tr			0.26	ns	20% to 80% Values
Optical Fall Time	tf			0.26	ns	20% to 80% Values
Relative Intensity Noise	RIN			-120	dB/Hz	
Total Jitter	TJ			0.227	ns	2
<b>Electrical</b>						
Data Input Current – Low	IIL	-350			$\mu$ A	
Data Input Current – High	IiH			350	$\mu$ A	
Differential Input Voltage	V <sub>IH</sub> - V <sub>IL</sub>	300			mV	
Data Input Voltage – Low	V <sub>IL</sub> - V <sub>CC</sub>	-2.0		-1.58	V	3
Data Input Voltage -- High	V <sub>IH</sub> - V <sub>CC</sub>	-1.1		-0.74	V	3

- Notes: 1. Output power is power coupled into a 9/125  $\mu$ m single mode fiber.  
 2. Measured with a 2<sup>7</sup>-1 PRBS.  
 3. These inputs are compatible with 10K, 10KH and 100K ECL and LVPECL inputs.

Receiver Specifications (0°C < Topr < 70°C, 4.75V < Vcc < 5.25V)						
Parameter	Symbol	Min	Typ	Max	Units	Notes
<b>Optical</b>						
Sensitivity	---	---	---	-22	dBm	1
Maximum Input Power	P <sub>in</sub>	-3		---	dBm	
Signal Detect -- Asserted	P <sub>a</sub>	---	---	-22	dBm	Transition: low to high
Signal Detect -- Deasserted	P <sub>d</sub>	-31	---	---	dBm	Transition: high to low
Signal detect -- Hysteresis		1.0	---		dB	
Wavelength of Operation		1100	---	1600	nm	
<b>Electrical</b>						
Data Output Voltage – Low	V <sub>OL</sub> - V <sub>CC</sub>	-2.0		-1.58	V	2
Data Output Voltage – High	V <sub>OH</sub> - V <sub>CC</sub>	-1.1		-0.74	V	2
Signal Detect Output Voltage -- Low	V <sub>OL</sub> - V <sub>CC</sub>	-2.0		-1.58	V	TRS-7020G
Signal Detect Output Voltage -- High	V <sub>OH</sub> - V <sub>CC</sub>	-1.1		-0.74	V	
Signal Detect Output Voltage -- Low	V <sub>SDL</sub>			0.5	V	TRS-7020CG
Signal Detect Output Voltage -- High	V <sub>SDH</sub>	2.0			V	

- Notes: 1. Minimum sensitivity and saturation levels at BER=1E-12 for a 2<sup>7</sup>-1 PRBS.  
 2. These outputs are compatible with 10K, 10KH and 100K ECL and PECL outputs.

### CONNECTION DIAGRAM

Receiver Signal Ground	1 (Rx GND)	○
Receiver Data Out	2 (RD+)	N/C
Receiver Data Out Bar	3 (RD-)	
Signal Detect	4 (SD)	
Receiver Power Supply	5 (Rx Vcc)	TOP VIEW
Transmitter Power Supply	6 (Tx Vcc)	
Transmitter Data In Bar	7 (TD-)	
Transmitter Data In	8 (TD+)	N/C
Transmitter Signal Ground	9 (Tx GND)	○

PIN	Symbol	Notes
1	Rx GND	Directly connect this pin to the receiver ground plane
2	RD+	See recommended circuit schematic
3	RD-	See recommended circuit schematic
4	SD	Active high on this indicates a received optical signal
5	Rx Vcc	+5V dc power for the receiver section
6	Tx Vcc	+5V dc power for the transmitter section
7	TD-	See recommended circuit schematic
8	TD+	See recommended circuit schematic
9	Tx GND	Directly connect this pin to the transmitter ground plane

### RECOMMENDED CIRCUIT SCHEMATIC

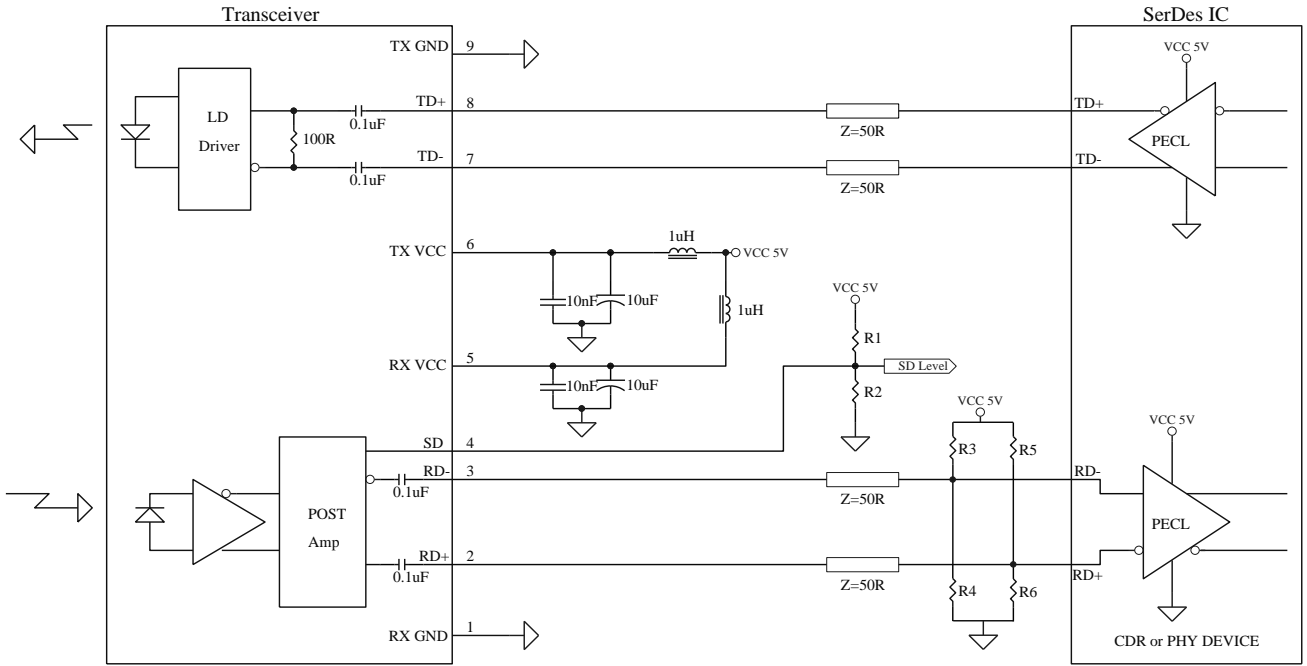

**For TTL SD Level, R1=R2=N.C., R3=R5=82R, R4=R6=130R**  
**For PECL SD Level, R1=R3=R5=82R, R2=R4=R6=130R**

The split-load terminations for ECL signals need to be located at the input of devices receiving those ECL signals. The power supply filtering is required for good EMI performance. Use short tracks from the inductor L1/L2 to the module Rx Vcc and Tx Vcc. A GND plane under the module is required for good EMI and sensitivity performance.

## PACKAGE DIAGRAM

Units in mm

### 1) SC Type With Extended Shielding

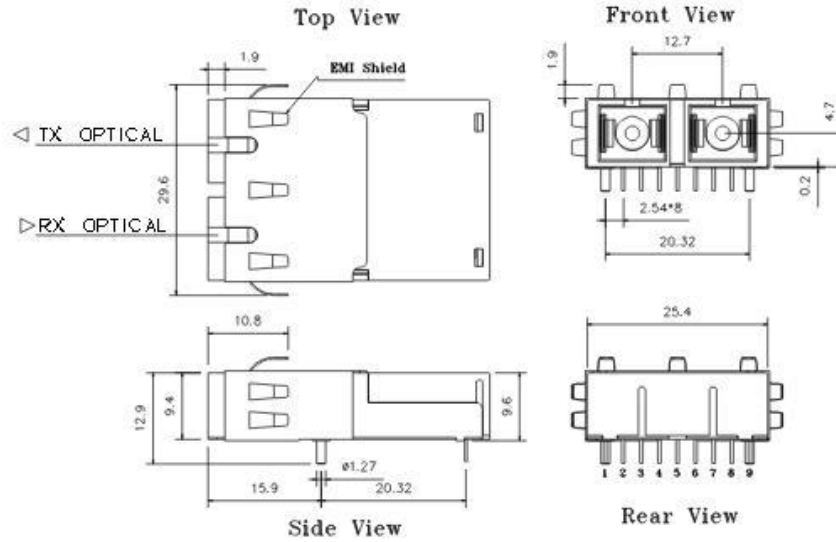

TRS-7020-EMG / TRS-7020C-EMG

### 2) ST Type

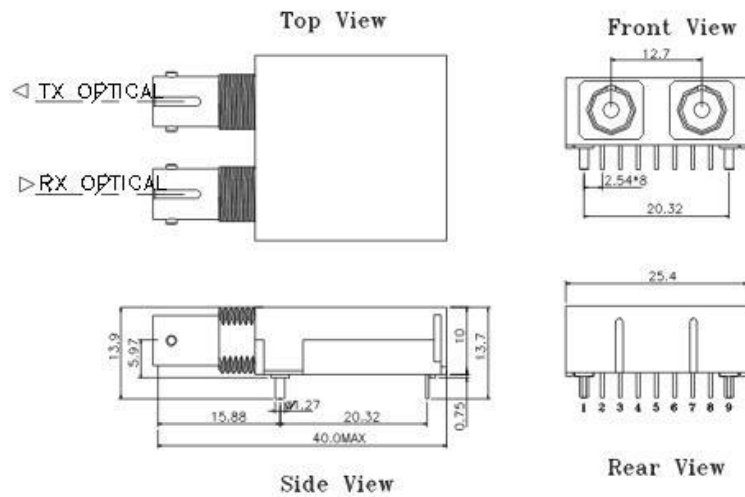

TRS-7020TG / TRS-7020CTG

### 3) FC Type

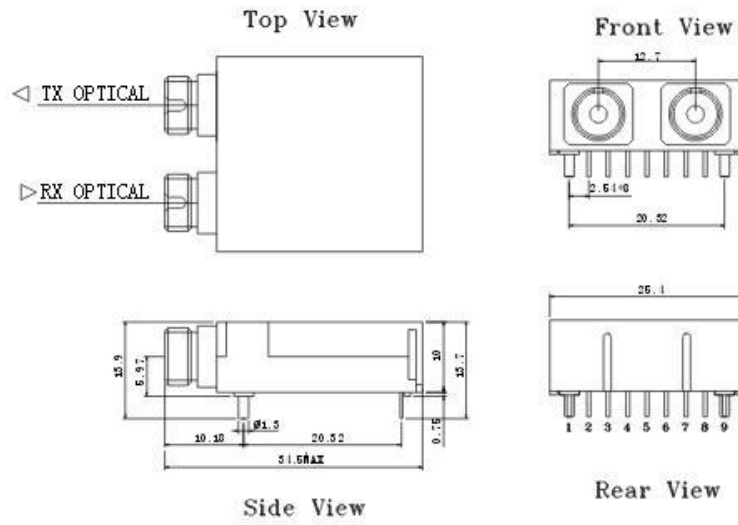

TRS-7020FG / TRS-7020CFG

**Note:** Specifications subject to change without notice.

\*\*\*\*\*  
**REVISION HISTORY**

<b>Version</b>	<b>Subject</b>	<b>Release Date</b>
5.0	Add -40 to 85°C version: TRS-7020AG	2025/1/10