

BTR-7700MG / BTR-7700-CMG / BTR-7700AMG / BTR-7700ACMG

1550 nm TX / 1310 nm RX , 3.3V / 1.25 Gb/s RoHS Compliant Single-Fiber MM Transceiver

FEATURES

- Single Fiber Bi-Directional MM Transceiver
- 1550 nm LD Transmitter
- 1310 nm Receiver
- Link distance 0 to 500 m
- Industry Standard 1 x 9 Footprint
- Single +3.3 V Power Supply
- RoHS Compliant
- 0 to 70°C Operating: BTR-7700MG
- -40 to 85°C Operating: BTR-7700AMG
- LVPECL Differential Inputs and Outputs
- LVPECL Signal Detect Output : BTR-7700MG
- LVTTTL Signal Detect Output : BTR-7700CMG
- Wave Solderable
- Class 1 Laser International Safety Standard IEC-60825 Compliant

APPLICATIONS

- WDM 1.25 Gb/s Links
- SONET / SDH Equipment Interconnect
- Fiber Channel 1.063 Gb/s Links

DESCRIPTION

The BTR-7700MG series are high performance modules for multi-mode single fiber communications by using 1550 nm transmitter and 1310nm receiver. The transmitter section uses a multiple quantum well laser and is a class 1 laser compliant according to International Safety Standard IEC-60825. The receiver section uses an integrated 1310 nm detector preamplifier (IDP) mounted in an optical header and a limiting post-amplifier IC. A PECL logic interface simplifies interface to external circuitry.

LASER SAFETY

This multi-mode transceiver is a Class 1 laser product. It complies with IEC-60825 and FDA 21 CFR 1040.10 and 1040.11. The transceiver must be operated within the specified temperature and voltage limits. The optical ports of the module shall be terminated with an optical connector or with a dust plug.

ORDER INFORMATION

P/No.	Bit Rate (Gb/s)	Distance (m)	TX (nm)	RX (nm)	Voltage (V)	Package	Temp. (°C)	TX Power (dBm)	RX Sens. (dBm)	RoHS Compliant
BTR-7700MG	1.25	0 to 500	1550	1310	3.3	1X9 SC	0 to 70	-4 to -10	-17	Yes
BTR-7700AMG	1.25	0 to 500	1550	1310	3.3	1X9 SC	-40 to 85	-4 to -10	-17	Yes

Absolute Maximum Ratings

Parameter	Symbol	Min	Max	Units	Notes
Storage Temperature	Tstg	-40	85	°C	
Operating Temperature	Topr	0 -40	70 85	°C	BTR-7700MG BTR-7700AMG
Soldering Temperature	---		260	°C	10 seconds on leads only
Power Supply Voltage	Vcc	0	4.5	V	
Input Voltage	---	GND	Vcc	V	
Output Current	Iout	0	30	mA	

Recommended Operating Conditions

Parameter	Symbol	Min	Typ	Max	Units / Notes
Power Supply Voltage	Vcc	3.13	3.3	3.47	V
Operating Temperature	Topr	0 -40		70 85	°C / BTR-7700MG °C / BTR-7700AMG
Data Rate			1250	1300	Mb/s
Power Supply Current	Icc			240	mA

Transmitter Specifications (0°C < Topr < 70°C, 3.13V < Vcc < 3.47V)

Parameter	Symbol	Min	Typ	Max	Units	Notes
Optical						
Optical Transmit Power	Po	-10	---	-4	dBm	1
Output Center Wavelength	λ	1480		1580	nm	
Output Spectrum Width	$\Delta\lambda$	---	---	4	nm	RMS(σ)
Output Eye	Compliant with IEEE 802.3z					
Optical Rise Time	tr			0.26	ns	20% to 80% Values
Optical Fall Time	tf			0.26	ns	20% to 80% Values
Relative Intensity Noise	RIN			-120	dB/Hz	
Total Jitter	TJ			0.227	ns	2
Electrical						
Data Input Current – Low	IIL	-350			μ A	
Data Input Current – High	IiH			350	μ A	
Differential Input Voltage	V _{IH} - V _{IL}	300			mV	
Data Input Voltage – Low	V _{IL} - V _{CC}	-2.0		-1.58	V	3
Data Input Voltage -- High	V _{IH} - V _{CC}	-1.1		-0.74	V	3

- Notes: 1. Output power is power coupled into a 62.5/125 μ m multi- mode fiber.
 2. Measured with a 2⁷-1 PRBS.
 3. These inputs are compatible with 10K, 10KH and 100K ECL and LVPECL inputs.

Receiver Specifications (0°C < Topr < 70°C, 3.13V < Vcc < 3.47V)

Parameter	Symbol	Min	Typ	Max	Units	Notes
Optical						
Sensitivity	---	---	---	-17	dBm	1
Maximum Input Power	Pin	-3		---	dBm	
Signal Detect -- Asserted	Pa	---	---	-17	dBm	Transition: low to high
Signal Detect -- Deasserted	Pd	-30	---	---	dBm	Transition: high to low
Signal detect -- Hysteresis		1.0	---		dB	
Wavelength of Operation		1260	---	1360	nm	2
Optical Return Loss	ORL	14			dB	
Electrical						
Data Output Voltage – Low	V _{OL} - V _{CC}	-2.0		-1.58	V	3
Data Output Voltage – High	V _{OH} - V _{CC}	-1.1		-0.74	V	3
SD Output Voltage -- Low	V _{OL} - V _{CC}	-2.0		-1.58	V	BTR-7700MG
SD Output Voltage -- High	V _{OH} - V _{CC}	-1.1		-0.74	V	
SD Output Voltage -- Low	V _{OL}	0		0.8	V	BTR-7700CMG
SD Output Voltage -- High	V _{OH}	2.0		V _{cc} + 0.3	V	

- Notes: 1. Minimum sensitivity and saturation levels at BER=1E-12 for a 2⁷-1 PRBS.
 2. At least 30 dB optical isolation for the wavelength 1480 to 1580 nm.
 3. These outputs are compatible with 10K, 10KH and 100K ECL and LVPECL outputs.

CONNECTION DIAGRAM

Receiver Signal Ground	1 (Rx GND)	○
Receiver Data Out	2 (RD+)	N/C
Receiver Data Out Bar	3 (RD-)	
Signal Detect	4 (SD)	
Receiver Power Supply	5 (Rx Vcc)	
Transmitter Power Supply	6 (Tx Vcc)	
Transmitter Data In Bar	7 (TD-)	
Transmitter Data In	8 (TD+)	N/C
Transmitter Signal Ground	9 (Tx GND)	○

TOP VIEW

PIN	Symbol	Notes
1	Rx GND	Directly connect this pin to the receiver ground plane
2	RD+	See recommended circuit schematic
3	RD-	See recommended circuit schematic
4	SD	Active high on this indicates a received optical signal
5	Rx Vcc	+3.3V dc power for the receiver section
6	Tx Vcc	+3.3V dc power for the transmitter section
7	TD-	See recommended circuit schematic
8	TD+	See recommended circuit schematic
9	Tx GND	Directly connect this pin to the transmitter ground plane

RECOMMENDED CIRCUIT SCHEMATIC

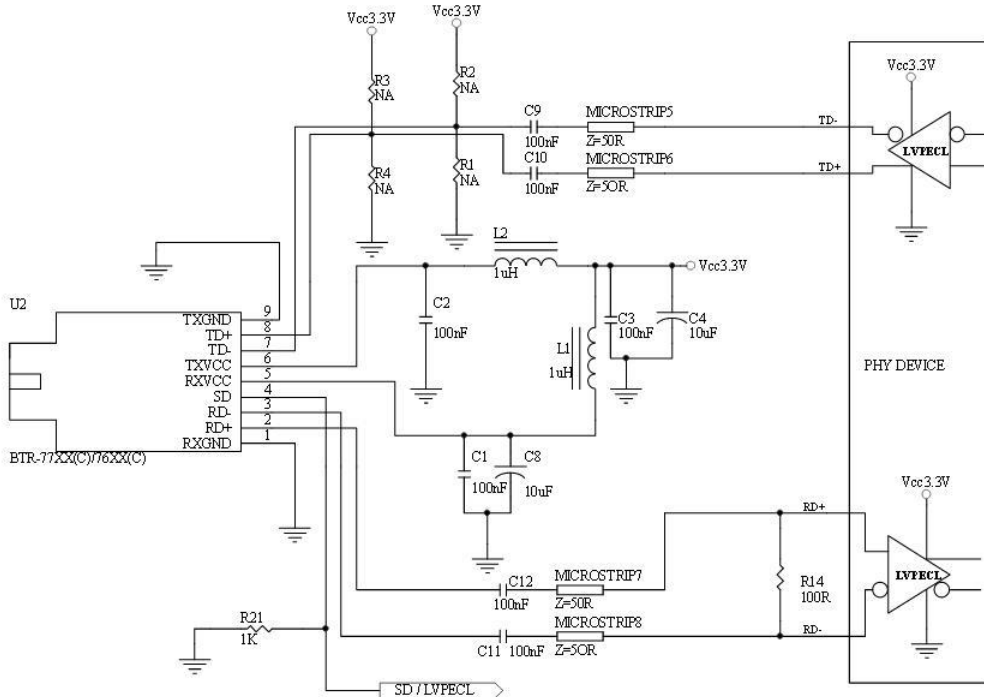

The split-load terminations for ECL signals need to be located at the input of devices receiving those ECL signals. The power supply filtering is required for good EMI performance. Use short tracks from the inductor L1/L2 to the module Rx Vcc and Tx Vcc. A GND plane under the module is required for good EMI and sensitivity performance.

PACKAGE DIAGRAM

Units in mm

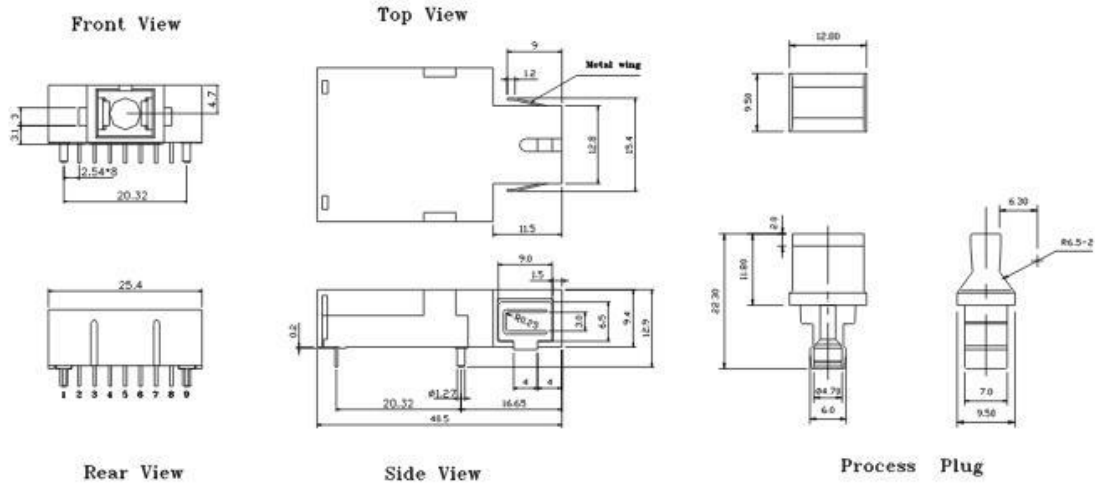

Note: Specifications subject to change without notice.

REVISION HISTORY

Version	Subject	Release Date
3.0	Update Operating Temp Range as -40 to 85C	2025/1/8