

**CSP-7620WG / CSP-7620BWG / CSP-7620AWG**

**(RoHS Compliant)**

**1.25 Gbps / 20km / 1310 nm TX & 1550 nm RX Digital Diagnostic 2-CH CSFP LC SM Transceiver**

**FEATURES**

- 2-Fiber Bi-Directional CSFP Optical Transceiver
- Up to 1.25 Gbps Bi-directional Data Links
- Compliant with CSFP MSA 2.0 (Option2)
- IEEE802.3ah 100BASE-BX, 1000BASE-BX, SONET OC-3 / SDH STM-1, Compliant
- SFF-8472 Digital Diagnostic Function
- Duplex LC Connector
- 1310 nm TX/1550nm RX
- Distance Up to 20 km
- AC/AC Coupling according to MSA
- Single +3.3 V Power Supply
- RoHS Compliant
- 0 to 70°C Operating: CSP-7620WG
- -10 to 85°C Operating: CSP-7620BWG
- -40 to 85°C Operating: CSP-7620AWG
- Class 1 Laser International Safety Standard IEC 60825 Compliant

**DESCRIPTION**

The CSP-7620WG series single mode transceiver is a small form factor pluggable module for bi-directional serial optical data communications such as IEEE 802.3ah 1000BASE-BX by using 1310 nm transmitter and 1550 nm receiver. It is with the SFP 20-pin connector to allow hot plug capability. Digital diagnostic functions are available via an I<sup>2</sup>C series bus specified in the SFP MSA SFF-8472. The transmitter section uses a multiple quantum well 1310 nm laser and is a class 1 laser compliant according to International Safety Standard IEC 60825. The receiver section uses an integrated 1550 nm detector preamplifier (IDP) mounted in an optical header and a limiting post-amplifier IC.

**LASER SAFETY**

This single mode transceiver is a Class 1 laser product. It complies with IEC 60825 and FDA 21 CFR 1040.10 and 1040.11. The transceiver must be operated within the specified temperature and voltage limits. The optical ports of the module shall be terminated with an optical connector or with a dust plug.

**APPLICATIONS**

- WDM Gigabit Ethernet Links
- SONET/SDH Equipment Interconnect
- Fibre Channel Links

**ORDER INFORMATION**

P/No.	Bit Rate (Gb/s)	1000BASE	Distance (km)	TX (nm)	RX (nm)	Package	Temp (°C)	RoHS Compliant
CSP-7620WG	1.25	BX	20	1310	1550	LC CSFP with DMI	0 to 70	Yes
CSP-7620BWG	1.25	BX	20	1310	1550	LC CSFP with DMI	-10 to 85	Yes
CSP-7620AWG	1.25	BX	20	1310	1550	LC CSFP with DMI	-40 to 85	Yes

Absolute Maximum Ratings					
Parameter	Symbol	Min	Max	Units	Notes
Storage Temperature	Tstg	-40	85	°C	
Operating Case Temperature	Topr	0	70	°C	CSP-7620WG
		-10	85		CSP-7620BWG
		-40	85		CSP-7620AWG
Relative Humidity	RH	0	85	%	Non condensing
Power Supply Voltage	Vcc	0	3.6	V	
Input Voltage	---	GND	Vcc	V	
Output Current	Iout	0	30	mA	

\*\*\*\*\*

Recommended Operating Conditions					
Parameter	Symbol	Min	Typ	Max	Units / Notes
Power Supply Voltage	V <sub>cc</sub>	3.13	3.3	3.47	V
Power Supply Current	I <sub>CC(TX+RX)</sub>			600	mA / 2 Channels
Operating Case Temperature	T <sub>opr</sub>	0		70	°C / CSP-7620WG
		-10		85	°C / CSP-7620BWG
		-40		85	°C / CSP-7620AWG
Data Rate			1.25		Gb/s

Transmitter Optical Specifications (3.13V < V <sub>cc</sub> < 3.47V)						
Parameter	Symbol	Min	Typ	Max	Units	Notes
Average Launch Power	P <sub>O, Avg</sub>	-6		+2	dBm	1
Extinction Ratio	ER	9				
Output Center Wavelength	λ <sub>c</sub>	1260	1310	1360	nm	
Output Spectrum Width	σ <sub>λ</sub>			IEEE802.3ah Table 59-4	nm	
Average Launch Power of OFF Transmitter				-45	dBm	

1. Output power is power coupled into a 9/125 μm single-mode fiber.

Receiver Optical Specifications (3.13V < V <sub>cc</sub> < 3.47V)						
Parameter	Symbol	Min	Typ	Max	Units	Notes
Sensitivity	S <sub>en</sub>			-25	dBm	2, Average Power
Receiver Overload	P <sub>MAX</sub>	-3	---		dBm	
LOS -- Deasserted	LOS <sub>D</sub>	---	---	-14	dBm	Transition: high to low
LOS -- Asserted	LOS <sub>A</sub>	-45	---	---	dBm	Transition: low to high
LOS Hysteresis	LOS <sub>H</sub>	0.5	2	6	dB	
Wavelength of Operation	λ <sub>c</sub>	1480		1600	nm	

2. Measured with average power; BER < 10<sup>-12</sup> and PRBS 2<sup>31</sup>-1 @ 1.25Gbps.

Electrical Characteristics						
Parameter	Symbol	Min	Typ	Max	Units	Notes
<b>High-Speed Signal (CML) Interface Specification</b>						
Input Data Rate			1.25		Gb/s	
Differential Data Input Amplitude		500		2400	mVpp	Internally AC coupled
Output Data Rate			1.25		Gb/s	
<b>Low-Speed Signal (LVTTTL) Interface Specification</b>						
Input High Voltage		2.0		V <sub>cc</sub>	V	
Input Low Voltage		GND		0.8	V	
Output High Voltage		2.0		V <sub>cc</sub>	V	
Output Low Voltage		GND		0.8	V	

CONNECTION DIAGRAM

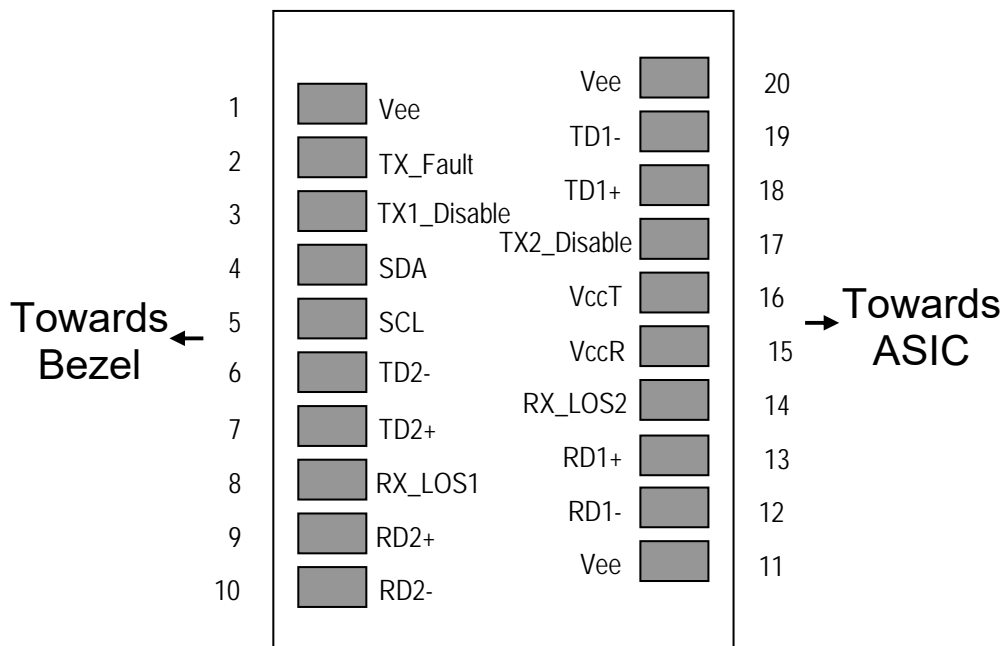

PIN	Signal Name	Description	PIN	Signal Name	Description
1	V <sub>EE</sub>	Transmitter Signal Ground	11	V <sub>EE</sub>	Receiver Signal Ground
2	TX_Fault	Transmitter Fault Indication. Logic "1" Output = Laser Fault. Logic "0" Output = Normal Operation	12	RD1-	Inverse Receiver Data Out Ch1
3	TX1_Disable	Logic "1" Input (or no connection) = Laser off, Logic "0" = Laser on.	13	RD1+	Receiver Data Out Ch1
4	SDA	Modulation Definition 2 – Two wires serial ID Interface	14	RX_LOS2	Loss of Signal Out Ch 2(OC).
5	SCL	Modulation Definition 1 – Two wires serial ID Interface	15	V <sub>CC</sub> R	Receiver Power – 3.3V±5%
6	TD2-	Transmitter Data In Ch2	16	V <sub>CC</sub> T	Transmitter Power – 3.3V±5%
7	TD2+	Inverse Transmitter Data In Ch2	17	TX2_Disable	Logic "1" Input (or no connection) = Laser off, Logic "0" = Laser on.
8	RX_LOS1	Loss of Signal Out Ch1(OC).	18	TD1+	Transmitter Data In Ch1
9	RD2+	Receiver Data Out Ch2	19	TD1-	Inverse Transmitter Data In Ch1
10	RD2-	Inverse Receiver Data Out Ch2	20	V <sub>EE</sub>	Transmitter Signal Ground

RECOMMENDED CIRCUIT SCHEMATIC

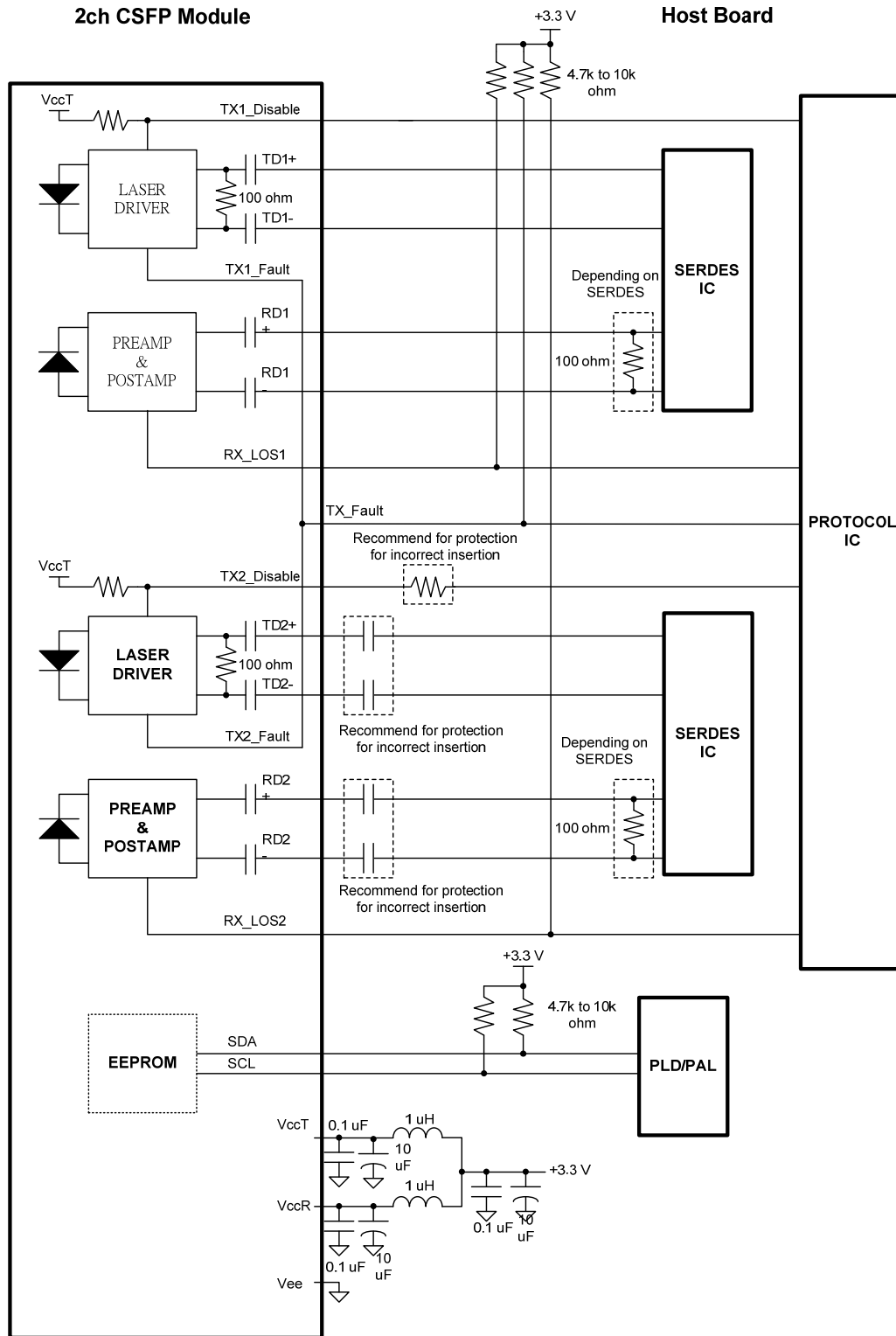

\*\*\*\*\*  
PACKAGE DIAGRAM

Units in mm

Top View

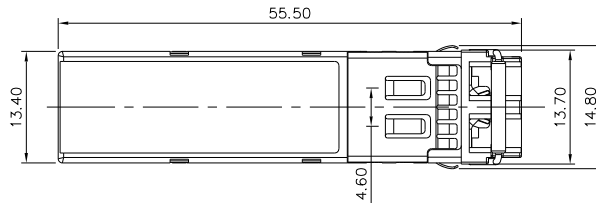

Front View

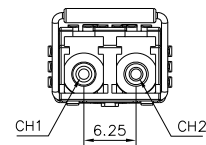
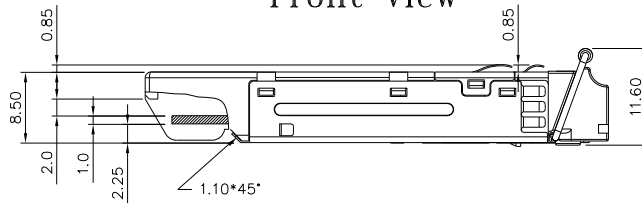

Side View

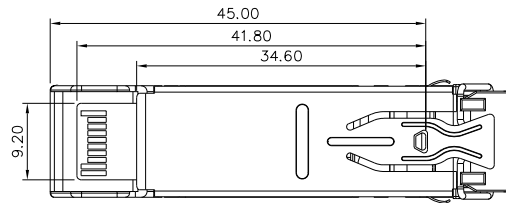

Bottom View

Note: Specifications subject to change without notice.

REVISION HISTORY

Version	Subject	Release Date
1.0	Initial datasheet	2021/4/8