

## GBS-9280-CXX0G

**(RoHS Compliant)**

### 5V / CWDM / 2.125 Gb/s Single-Mode Gigabit Interface Converter (GBIC)

#### FEATURES

- I 18-Wavelength CWDM GBIC Transceivers
- I 2.5 Gbps Bi-directional Data Links
- I Compliant with 1X / 2X Fibre Channel FC-PI 13.0
- I Compliant with Gigabit Interface Converter (GBIC) Specification Rev. 5.5
- I CWDM DFB Laser Transmitter
- I APD High Sensitivity Receiver
- I Multi-rate Operation for 2.5 / 2.125 / 1.062 / 1.25 Gbps
- I Duplex SC Connector
- I 28 dB Power Budget At Least
- I SCA-2 Host Connector
- I Single +5 V Power Supply
- I RoHS Compliant
- I Differential PECL Inputs and Outputs
- I TTL RX-LOS Output
- I Hot Pluggable
- I Class 1 Laser International Safety Standard IEC-60825 Compliant

#### DESCRIPTION

The GBS-9280-CXX0G series optical transceivers meet the Gigabit Interface Converter (GBIC) specification Rev. 5.5. It satisfies the optical interface specifications defined in IEEE 802.3z Drift 5.0 1000 BASE for Gigabit Ethernet and 1x/2x Fiber Channel FC-PI13.0. This module is designed for single-mode fiber and operates at a nominal wavelength of CWDM. There are eighteen center wavelengths available from 1270 nm to 1610 nm, each step 20 nm. A guaranteed minimum optical link budget of 28 dB is offered. The transmission distance is depended on the wavelength and loss of fiber. The transmitter section uses a multiple quantum well CWDM DFB laser and is a class 1 laser compliant according to International Safety Standard IEC-60825. The receiver section uses an integrated InGaAs detector preamplifier (IDP) mounted in an optical header and a limiting post-amplifier IC. A PECL input / output logic interface is used. TTL RX-LOS output simplifies interface to external circuitry. A 20-pin SCA-2 host connector is used to connect the converter to the host system.

#### APPLICATIONS

- I Switch to Switch Interface
- I High Speed Interface for File Servers
- I Bus Extension Application
- I Data Storage
- I Dual Rate 1.06 / 2.125 Gb/s Fibre Channel

#### LASER SAFETY

This single mode transceiver is a Class 1 laser product. It complies with IEC-60825 and FDA 21 CFR 1040.10 and 1040.11. The transceiver must be operated within the specified temperature and voltage limits. The optical ports of the module shall be terminated with an optical connector or with a dust plug.

#### ORDER INFORMATION

P/No.	Bit Rate (Gb/s)	Power Budget (dB)	Wavelength (nm)	Package	Temp. (°C)	TX Power (dBm)	RX Sens. (dBm)	RoHS Compliant
GBS-9280-CXX0	2.5	> 28	CWDM*	SC GBIC	0 to 70	5 to 0	-28	Yes

#### CWDM Wavelength (0 to 70°C)

Central Wavelength	Min. (nm)	Typ. (nm)	Max. (nm)	Central Wavelength	Min. (nm)	Typ. (nm)	Max. (nm)
-C270	1264.5	1270	1277.5	-C450	1444.5	1450	1457.5
-C290	1284.5	1290	1297.5	-C470	1464.5	1470	1477.5
-C310	1304.5	1310	1317.5	-C490	1484.5	1490	1497.5
-C330	1324.5	1330	1337.5	-C510	1504.5	1510	1517.5
-C350	1344.5	1350	1357.5	-C530	1524.5	1530	1537.5
-C370	1364.5	1370	1377.5	-C550	1544.5	1550	1557.5
-C390	1384.5	1390	1397.5	-C570	1564.5	1570	1577.5
-C410	1404.5	1410	1417.5	-C590	1584.5	1590	1597.5
-C430	1424.5	1430	1437.5	-C610	1604.5	1610	1617.5

CWDM\*: 18 Wavelengths from 1270 nm to 1610 nm, each step 20 nm.

Absolute Maximum Ratings						
Parameter	Symbol	Min	Max	Units	Notes	
Storage Temperature	T <sub>stg</sub>	-40	85	°C		
Operating Temperature	T <sub>opr</sub>	-5	70	°C	Air flow 1m/sec	
Power Supply Voltage	V <sub>cc</sub>	-0.5	6	V		
Input Voltage	---	-0.5	V <sub>cc</sub>	V		

Recommended Operating Conditions						
Parameter	Symbol	Min	Typ	Max	Units	Conditions
Power Supply Voltage	V <sub>cc</sub>	4.75	5	5.25	V	Reference to GND.
Power Supply Current	I <sub>TX</sub> + I <sub>RX</sub>		200	300	mA	
Operating Temperature	T <sub>opr</sub>	0		70	°C	Air flow 1m/sec
Data Rate			1.0625 / 1.25 2.125 / 2.5	2.5	Gb/s	

Transmitter Specifications (0°C < T <sub>opr</sub> < 70°C, 4.75V < V <sub>cc</sub> < 5.25V)						
Parameter	Symbol	Min	Typ	Max	Units	Notes
<b>Optical</b>						
Optical Transmit Power	P <sub>o</sub>	0	---	5	dBm	1
Output Center Wavelength	λ	λ-5.5	λ	λ+7.5	nm	2
Output Spectrum Width	Δλ		---	1	nm	-20 dB Width
Side Mode Suppression Ratio	SMSR	30			dB	
Extinction Ratio	E <sub>R</sub>		9	---	dB	
Optical Rise Time	t <sub>r</sub>			150	ps	20% to 80% value
Optical Fall Time	t <sub>f</sub>			150	ps	20% to 80% value
<b>Electrical</b>						
Differential Input Voltage	V <sub>IH</sub> - V <sub>IL</sub>	0.65		2.0	V <sub>p-p</sub>	
Transmit Fault Load	TX-FAULT <sub>LOAD</sub>	4.7		10	kΩ	3
Transmit Fault Output-Low	V <sub>TX-FAULT-L</sub>	0.0		0.5	V	
Transmit Fault Output-High	V <sub>TX-FAULT-H</sub>	V <sub>cc</sub> - 0.5		V <sub>cc</sub> + 0.3	V	
TX-Disable Input - Low	V <sub>TX-DISABLE-L</sub>	0		0.8	V	
TX-Disable Input - High	V <sub>TX-DISABLE-H</sub>	2.0		V <sub>cc</sub> + 0.3	V	
TX-Disable Assert Time	t <sub>off</sub>			10	μs	
TX-Disable Negate Time	t <sub>on</sub>			1	ms	
Time to initialize, includes reset of TX-FAULT	t <sub>int</sub>			300	ms	
TX FAULT from fault to assertion	t <sub>fault</sub>			100	μs	
TX-Disable time to start reset	t <sub>reset</sub>	10			μs	

1. Output power is power coupled into a 9/125 μm SM fiber.
2. ITU-T G.694.2 CWDM wavelength from 1270 nm to 1610 nm, each step 20 nm.
3. Pull-up resistor on host V<sub>cc</sub>.

\*\*\*\*\*

Receiver Specifications (0°C < Topr < 70°C, 4.75 V < Vcc < 5.25V)						
Parameter	Symbol	Min	Typ	Max	Units	Notes
<b>Optical</b>						
Sensitivity @2.125Gb/s @ BER=10 <sup>-12</sup>	SENS	---	---	-28	dBm	4
Maximum Input Power	Pin	-9		---	dBm	4
Signal detect – Hysteresis		1.0	---		dB	
Wavelength of Operation		1260	---	1620	nm	
RX-LOS – Asserted	Pa	---	---	-28	dBm	Transition: low to high
RX-LOS – Deasserted	Pd	-40	---	---	dBm	Transition: high to low
<b>Electrical</b>						
Differential Output Voltage	±RX-DAT	0.37		2.0	Vp-p	
Data Output Rise Time	T <sub>IRX-DAT</sub>			0.35	ns	
Data Output Fall Time	T <sub>FRX-DAT</sub>			0.35	ns	
Receiver Loss of Light Load	RX-LOS <sub>LOAD</sub>	4.7		10	kΩ	5
Loss of Signal Output Voltage --- Low	RX-LOS <sub>L</sub>	0		0.5	V	
Loss of Signal Output Voltage --- High	RX-LOS <sub>H</sub>	2.4		Vcc	V	
Loss of Signal Assert Time (off to on)	T <sub>A,RX-LOS</sub>			100	μs	
Loss of Signal Deassert Time (on to off)	T <sub>D,RX-LOS</sub>			100	μs	

4. Minimum sensitivity and saturation levels at BER=1E-12 for a 2<sup>7</sup>-1 PRBS.

5. Pull-up resistor on host Vcc.

\*\*\*\*\*

PIN ASSIGNMENT

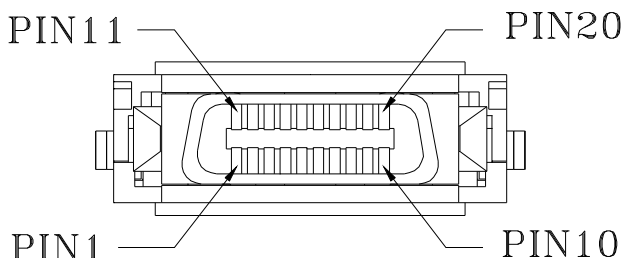

PIN	Signal Name	Sequence	Description
1	RX-LOS	2	Receiver Loss of Signal, logic high, open collector compatible, 4.7K to 10K ohm pull-up to V <sub>CC</sub> T on host
2	R <sub>GND</sub>	2	Receiver Ground
3	R <sub>GND</sub>	2	Receiver Ground
4	MOD-DEF(0)	2	TTL Low
5	MOD-DEF(1)	2	SCL Serial Clock Signal
6	MOD-DEF(2)	2	SDA Serial Data Signal
7	TX-DIABLE	2	Transmitter Disable, logic high, open collector compatible
8	T <sub>GND</sub>	2	Transmitter Ground
9	T <sub>GND</sub>	2	Transmitter Ground
10	TX-FAULT	2	Transmitter Fault, logic high, open collector compatible, 4.7K to 10K ohm pull-up to V <sub>CC</sub> T on GBIC
11	R <sub>GND</sub>	1	Receiver Ground
12	-RX-DAT	1	Receiver Data Bar, Differential PECL, AC coupled
13	+RX-DAT	1	Receiver Data, Differential PECL, AC coupled
14	R <sub>GND</sub>	1	Receiver Ground
15	V <sub>CC</sub> R	2	Receiver +3.3V Supply
16	V <sub>CC</sub> T	2	Transmitter +3.3V Supply
17	T <sub>GND</sub>	1	Transmitter Ground
18	+TX-DAT	1	Transmitter Data, Differential PECL, AC coupled
19	-TX-DAT	1	Transmitter Data Bar, Differential PECL, AC coupled
20	T <sub>GND</sub>	1	Transmitter Ground

A sequence value of 1 indicates that the signal is in the first group to engage during plugging of a module. A sequence value of 2 indicates that the signal is the second and last group. The two guide pins on the connector are electrically connected to the transceiver circuit ground. These two guide pins make contact with circuit prior to sequence 1 signals.

### Module Definition

Module Definition	MOD-DEF(0) PIN 4	MOD-DEF (1) PIN 5	MOD-DEF (2) PIN 6	Interpretation by Host
4	TTL Low	SCL	SDA	Serial module definition protocol

Module Definition 4 specifies a serial definition protocol. For this definition, upon power up, MOD-DEF(1:2) appear as no connector (NC) and MOD-DEF(0) is TTL LOW. When the host system detects this condition, it activates the serial protocol. The protocol uses the 2-wire serial CMOS E<sup>2</sup>PROM protocol of the ATMEL AT24C01A/02/04 family of components.

PACKAGE DIAGRAM

Units in mm

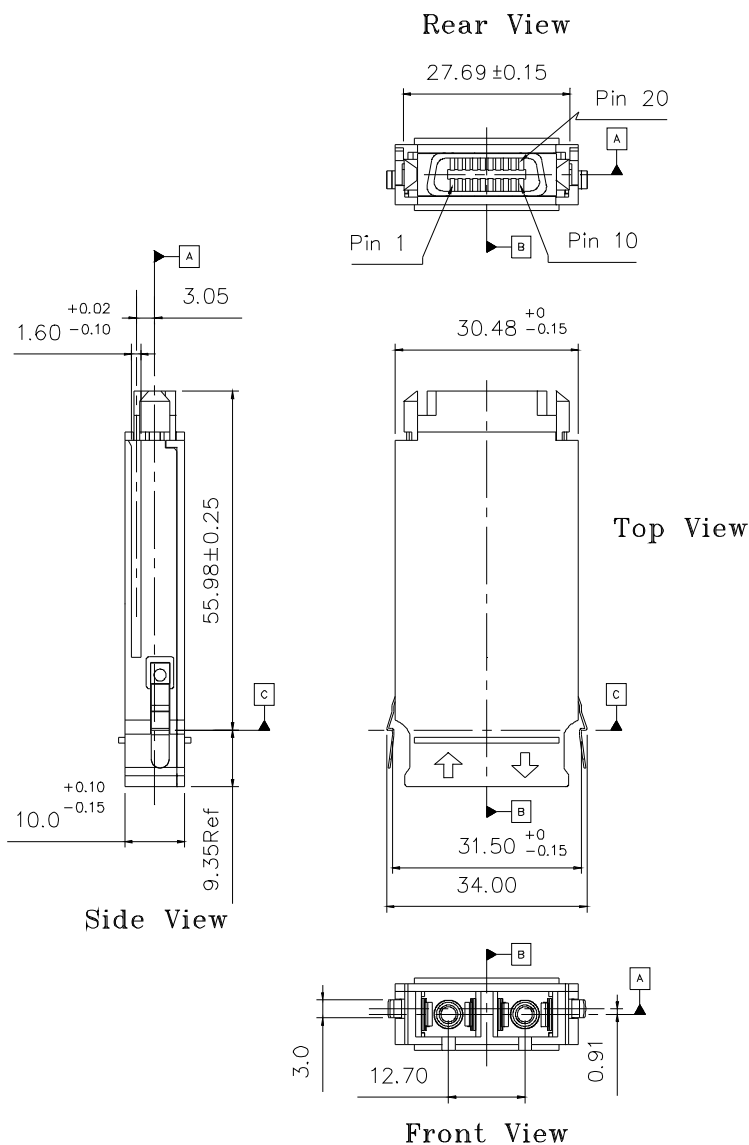

**Note:** Specifications subject to change without notice.