

GBB-7940G

(RoHS Compliant)

1490 nm TX / 1310 nm RX , 5V / 1.25 Gbps Single-Mode WDM Gigabit Interface Converter (GBIC)

FEATURES

- | 1-Fiber SM Gigabit Interface Converter (GBIC)
- | Compliant with GBIC Specification Rev. 5.5
- | Compliant with IEEE-802.3ah 1000BASE-BX
- | Compliant with Fibre Channel FC-PH-2 for 100-M5-SN-1 and 100-M6-SN-1
- | Hot Pluggable Module with SC Connector
- | 1490 nm LD Transmitter
- | 1310 nm Receiver
- | Up to 40 km using Single-mode Optic Cable
- | SCA-2 Host Connector
- | Single +5 V Power Supply
- | RoHS Compliant
- | Differential PECL Inputs and Outputs
- | TTL RX-LOS Output
- | Class 1 Laser International Safety Standard IEC 60825 Compliant

APPLICATIONS

- | WDM Gigabit Ethernet Links
- | SONET/SDH Equipment Interconnect
- | Fibre Channel Links

DESCRIPTION

The GBB-7940G series single-mode optical transceivers meet the Gigabit Interface Converter (GBIC) specification Rev. 5.5. It satisfies the optical interface specifications defined in IEEE 802.3ah 1000BASE BX by using 1490 nm transmitter and 1310 nm receiver. The transmitter section uses a multiple quantum well DFB laser and is a class 1 laser compliant according to International Safety Standard IEC 60825. The receiver section uses an integrated 1310 nm detector preamplifier (IDP) mounted in an optical header and a limiting post-amplifier IC. A PECL input / output logic interface is used. TTL RX-LOS output simplifies interface to external circuitry. A 20-pin SCA-2 host connector is used to connect the converter to the host system.

LASER SAFETY

This single mode transceiver is a Class 1 laser product. It complies with IEC 60825 and FDA 21 CFR 1040.10 and 1040.11. The transceiver must be operated within the specified temperature and voltage limits. The optical ports of the module shall be terminated with an optical connector or with a dust plug.

ORDER INFORMATION

P/No.	Bit Rate (Gb/s)	Distance (km)	TX (nm)	RX (nm)	Package	Temp (°C)	TX Power (dBm)	RX Sens. (dBm)	RoHS Compliant
GBB-7940G	1.25	40	1490 DFB	1310	SC GBIC	0 to 70	2 to -3	-23	Yes

Absolute Maximum Ratings					
Parameter	Symbol	Min	Max	Units	Notes
Storage Temperature	Tstg	-40	85	°C	
Operating Case Temperature	Topr	-5	70	°C	
Power Supply Voltage	Vcc	-0.5	6	V	
Input Voltage	---	-0.5	Vcc	V	
Relative Humidity	RH	5	95	%	

Recommended Operating Conditions					
Parameter	Symbol	Min	Typ	Max	Units
Power Supply Voltage	Vcc	4.75	5	5.25	V
Power Supply Current	I _{TX} + I _{RX}		200	300	mA
Operating Case Temperature	Topr	0		70	°C
Data Rate		1000	1250		Mb/s

Transmitter Specifications (0°C < Topr < 70°C, 4.75V < Vcc < 5.25V)						
Parameter	Symbol	Min	Typ	Max	Units	Notes
Optical						
Optical Transmit Power	Po	-3	---	2	dBm	1
Output Center Wavelength	λ	1480		1500	nm	
Output Spectrum Width	$\Delta\lambda$			1	nm	-20 dB width
Side Mode Suppression Ratio	SMSR	30			dB	
Extinction Ratio	ER	9			dB	
Optical Rise Time	t _r			0.26	ns	20% to 80% value
Optical Fall Time	t _f			0.26	ns	20% to 80% value
Relative Intensity Noise	RIN			-120	dB/Hz	
Total Jitter	TJ			227	ps	2
Max. Po at TX-Disable Asserted				-35	dBm	
Electrical						
Differential Input Voltage	V _{IH} - V _{IL}	0.65		2.0	Vp-p	
Transmit Fault Load	TX-FAULT _{LOAD}	4.7		10	k Ω	3
Transmit Fault Output-Low	V _{TX-FAULT-L}	0.0		0.5	V	
Transmit Fault Output-High	V _{TX-FAULT-H}	V _{CC} - 0.5		V _{CC} + 0.3	V	
TX-Disable Input - Low	V _{TX-DISABLE-L}	0		0.8	V	
TX-Disable Input - High	V _{TX-DISABLE-H}	2.0		V _{CC} + 0.3	V	
TX-Disable Assert Time	t _{off}			10	μ s	
TX-Disable Negate Time	t _{on}			1	ms	
Time to initialize, includes reset of TX-FAULT	t _{int}			300	ms	
TX FAULT from fault to assertion	t _{fault}			100	μ s	
TX-Disable time to start reset	t _{reset}	10			μ s	

- Notes: 1. Output power is power coupled into a 9/125 μ m single mode fiber.
 2. Measured with a 2⁷-1 PRBS.
 3. Pull-up resistor on host Vcc.

Receiver Specifications (0°C < Topr < 70°C, 4.75 V < Vcc < 5.25V)						
Parameter	Symbol	Min	Typ	Max	Units	Notes
Optical						
Sensitivity	---	---	---	-23	dBm	4
Maximum Input Power	Pin	-3		---	dBm	4
Signal detect – Hysteresis		1.0	---		dB	
Wavelength of Operation		1260		1360	nm	5
Optical Return Loss	ORL	12			dB	
RX-LOS – Asserted	Pa	---	---	-23	dBm	Transition: low to high
RX-LOS – Deasserted	Pd	-36	---	---	dBm	Transition: high to low
Electrical						
Differential Output Voltage	V _{OH} - V _{OL}	0.37		2.0	Vp-p	
Data Output Rise Time	T _{IRX-DAT}			0.35	ns	
Data Output Fall Time	T _{FRX-DAT}			0.35	ns	
RX-LOS of Light Load	RX-LOS _{LOAD}	4.7		10	k Ω	6
RX-LOS Output Voltage --- Low	V _{RX-LOS-L}	0		0.5	V	
RX-LOS Output Voltage --- High	V _{RX-LOS-H}	2.4		V _{CC}	V	
RX-LOS Assert Time (off to on)	T _{A,RX-LOS}			100	μ s	
RX-LOS Deassert Time (on to off)	T _{D,RX-LOS}			100	μ s	

- Notes: 4. Minimum sensitivity and saturation levels at BER=1E-12 for a 2⁷-1 PRBS.
 5. At least 30 dB optical isolation for the wavelength 1480 to 1500 nm.
 6. Pull-up resistor on host Vcc.

PIN ASSIGNMENT

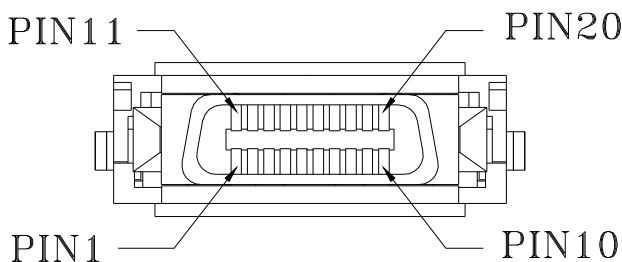

PIN	Signal Name	Sequence	Description
1	RX-LOS	2	Receiver Loss of Signal, logic high, open collector compatible, 4.7K to 10K ohm pull-up to V _{CC} T on host
2	R _{GND}	2	Receiver Ground
3	R _{GND}	2	Receiver Ground
4	MOD-DEF(0)	2	TTL Low
5	MOD-DEF(1)	2	SCL Serial Clock Signal
6	MOD-DEF(2)	2	SDA Serial Data Signal
7	TX-DIABLE	2	Transmitter Disable, logic high, open collector compatible
8	T _{GND}	2	Transmitter Ground
9	T _{GND}	2	Transmitter Ground
10	TX-FAULT	2	Transmitter Fault, logic high, open collector compatible, 4.7K to 10K ohm pull-up to V _{CC} T on GBIC
11	R _{GND}	1	Receiver Ground
12	-RX-DAT	1	Receiver Data Bar, Differential PECL, AC coupled
13	+RX-DAT	1	Receiver Data, Differential PECL, AC coupled
14	R _{GND}	1	Receiver Ground
15	V _{CC} R	2	Receiver +5V Supply
16	V _{CC} T	2	Transmitter +5V Supply
17	T _{GND}	1	Transmitter Ground
18	+TX-DAT	1	Transmitter Data, Differential PECL, AC coupled
19	-TX-DAT	1	Transmitter Data Bar, Differential PECL, AC coupled
20	T _{GND}	1	Transmitter Ground

A sequence value of 1 indicates that the signal is in the first group to engage during plugging of a module. A sequence value of 2 indicates that the signal is the second and last group. The two guide pins on the connector are electrically connected to the transceiver circuit ground. These two guide pins make contact with circuit prior to sequence 1 signals.

Module Definition

Module Definition	MOD-DEF(0) PIN 4	MOD-DEF (1) PIN 5	MOD-DEF (2) PIN 6	Interpretation by Host
4	TTL Low	SCL	SDA	Serial module definition protocol

Module Definition 4 specifies a serial definition protocol. For this definition, upon power up, MOD-DEF(1:2) appear as no connector (NC) and MOD-DEF(0) is TTL LOW. When the host system detects this condition, it activates the serial protocol. The protocol uses the 2-wire serial CMOS E²PROM protocol of the ATMEL AT24C01A/02/04 family of components.

PACKAGE DIAGRAM

Units in mm

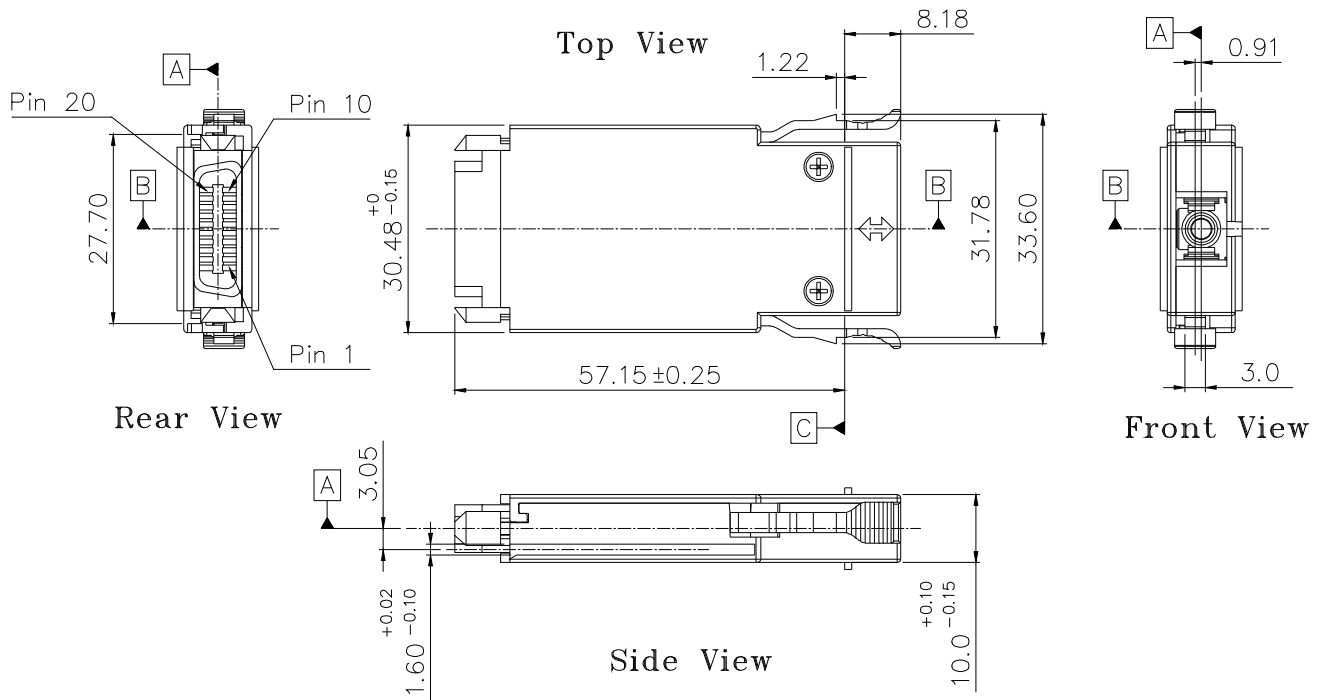

Note: Specifications subject to change without notice.