

## GBS-7030G

**(RoHS Compliant)**

### 5V / 1310 nm / 1.25 Gbps Single-Mode Gigabit Interface Converter (GBIC)

#### FEATURES

- | Compliant with Gigabit Interface Converter (GBIC) Specification Rev. 5.5
- | Compliant with IEEE-802.3z / D5.0 Gigabit Ethernet 1000BASE
- | Hot Pluggable Module with Duplex SC Connector
- | 30 km using Single-mode Optic Cable
- | 19 dB Power Budget at Least
- | SCA-2 Host Connector
- | Single +5 V Power Supply
- | RoHS Compliant
- | Differential PECL Inputs and Outputs
- | TTL RX-LOS Output
- | Class 1 Laser International Safety Standard IEC-60825 Compliant

#### DESCRIPTION

The GBS-7030G series optical transceivers meet the Gigabit Interface Converter (GBIC) specification Rev. 5.5. It satisfies the optical interface specifications defined in IEEE 802.3z Drift 5.0 for Gigabit Ethernet. This module is designed for single mode fiber and operates at a nominal wavelength of 1310 nm. The transmitter section uses a multiple quantum well laser and is a class 1 laser compliant according to International Safety Standard IEC-60825. The receiver section uses an integrated InGaAs detector preamplifier (IDP) mounted in an optical header and a limiting post-amplifier IC. A PECL input / output logic interface is used. TTL RX-LOS output simplifies interface to external circuitry. A 20-pin SCA-2 host connector is used to connect the converter to the host system.

#### APPLICATIONS

- | Switch to Switch Interface
- | High Speed Interface for File Servers
- | Bus Extension Application
- | Data Storage

#### LASER SAFETY

This single mode transceiver is a Class 1 laser product. It complies with IEC-60825 and FDA 21 CFR 1040.10 and 1040.11. The transceiver must be operated within the specified temperature and voltage limits. The optical ports of the module shall be terminated with an optical connector or with a dust plug.

#### ORDER INFORMATION

P/No.	Bit Rate (Gb/s)	1000 BASE	Distance (km)	Wavelength (nm)	Package	Temp. (°C)	TX Power (dBm)	RX Sens. (dBm)	RoHS Compliant
GBS-7030G	1.25		30	1310	SC GBIC	0 to 70	0 to -5	-24	Yes

#### Absolute Maximum Ratings

Parameter	Symbol	Min	Max	Units	Notes
Storage Temperature	Tstg	-40	85	°C	
Operating Temperature	Topr	-5	70	°C	
Power Supply Voltage	Vcc	-0.5	6	V	
Input Voltage	---	-0.5	Vcc	V	
Relative Humidity	RH	5	95	%	

#### Recommended Operating Conditions

Parameter	Symbol	Min	Typ	Max	Units
Power Supply Voltage	Vcc	4.75	5	5.25	V
Power Supply Current	I <sub>TX</sub> + I <sub>RX</sub>		200	300	mA
Operating Temperature	Topr	0		70	°C
Data Rate		1000	1250		Mb/s

Transmitter Specifications (0°C < Topr < 70°C, 4.75V < Vcc < 5.25V)						
Parameter	Symbol	Min	Typ	Max	Units	Notes
<b>Optical</b>						
Optical Transmit Power	Po	-5	---	0	dBm	1
Output Center Wavelength	$\lambda$	1285	1310	1350	nm	
Output Spectrum Width	$\Delta\lambda$	---	---	1.8	nm	RMS ( $\sigma$ )
Extinction Ratio	ER		9	---	dB	
Coupled Power Ratio	CPR	9			dB	
Optical Rise Time	t <sub>r</sub>			0.26	ns	20% to 80% value
Optical Fall Time	t <sub>f</sub>			0.26	ns	20% to 80% value
Relative Intensity Noise	RIN			-120	dB/Hz	
Total Jitter	TJ			227	ps	2
Max. Po at TX-Disable Asserted				-35	dBm	
<b>Electrical</b>						
Differential Input Voltage	V <sub>IH</sub> - V <sub>IL</sub>	0.65		2.0	Vp-p	
Transmit Fault Load	TX-FAULT <sub>LOAD</sub>	4.7		10	k $\Omega$	3
Transmit Fault Output-Low	V <sub>TX-FAULT-L</sub>	0.0		0.5	V	
Transmit Fault Output-High	V <sub>TX-FAULT-H</sub>	V <sub>CC</sub> - 0.5		V <sub>CC</sub> + 0.3	V	
TX-Disable Input - Low	V <sub>TX-DISABLE-L</sub>	0		0.8	V	
TX-Disable Input - High	V <sub>TX-DISABLE-H</sub>	2.0		V <sub>CC</sub> + 0.3	V	
TX-Disable Assert Time	t <sub>off</sub>			10	$\mu$ s	
TX-Disable Negate Time	t <sub>on</sub>			1	ms	
Time to initialize, includes reset of TX-FAULT	t <sub>int</sub>			300	ms	
TX FAULT from fault to assertion	t <sub>fault</sub>			100	$\mu$ s	
TX-Disable time to start reset	t <sub>reset</sub>	10			$\mu$ s	

- Notes: 1. Output power is power coupled into a 9/125  $\mu$ m single mode fiber.  
 2. Measured with a 2<sup>7</sup>-1 PRBS.  
 3. Pull-up resistor on host Vcc.

Receiver Specifications (0°C < Topr < 70°C, 4.75 V < Vcc < 5.25V)						
Parameter	Symbol	Min	Typ	Max	Units	Notes
<b>Optical</b>						
Sensitivity	---	---	---	-24	dBm	4
Maximum Input Power	Pin	-3		---	dBm	4
Signal detect – Hysteresis		1.0	---		dB	
Wavelength of Operation		1100	---	1600	nm	
Optical Return Loss	ORL	12			dB	
RX-LOS – Asserted	Pa	---	---	-24	dBm	Transition: low to high
RX-LOS – Deasserted	Pd	-36	---	---	dBm	Transition: high to low
<b>Electrical</b>						
Differential Output Voltage	V <sub>OH</sub> - V <sub>OL</sub>	0.37		2.0	Vp-p	
Data Output Rise Time	T <sub>IRX-DAT</sub>			0.35	ns	
Data Output Fall Time	T <sub>FRX-DAT</sub>			0.35	ns	
RX-LOS of Light Load	RX-LOS <sub>LOAD</sub>	4.7		10	k $\Omega$	5
RX-LOS Output Voltage --- Low	V <sub>RX-LOS-L</sub>	0		0.5	V	
RX-LOS Output Voltage --- High	V <sub>RX-LOS-H</sub>	2.4		V <sub>CC</sub>	V	
RX-LOS Assert Time (off to on)	T <sub>A,RX-LOS</sub>			100	$\mu$ s	
RX-LOS Deassert Time (on to off)	T <sub>D,RX-LOS</sub>			100	$\mu$ s	

- Notes: 4. Minimum sensitivity and saturation levels at BER=1E-12 for a 2<sup>7</sup>-1 PRBS.  
 5. Pull-up resistor on host Vcc.

PIN ASSIGNMENT

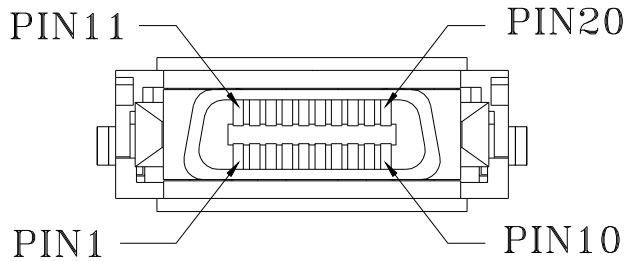

PIN	Signal Name	Sequence	Description
1	RX-LOS	2	Receiver Loss of Signal, logic high, open collector compatible, 4.7K to 10K ohm pull-up to V <sub>CC</sub> T on host
2	R <sub>GND</sub>	2	Receiver Ground
3	R <sub>GND</sub>	2	Receiver Ground
4	MOD-DEF(0)	2	TTL Low
5	MOD-DEF(1)	2	SCL Serial Clock Signal
6	MOD-DEF(2)	2	SDA Serial Data Signal
7	TX-DIABLE	2	Transmitter Disable, logic high, open collector compatible
8	T <sub>GND</sub>	2	Transmitter Ground
9	T <sub>GND</sub>	2	Transmitter Ground
10	TX-FAULT	2	Transmitter Fault, logic high, open collector compatible, 4.7K to 10K ohm pull-up to V <sub>CC</sub> T on GBIC
11	R <sub>GND</sub>	1	Receiver Ground
12	-RX-DAT	1	Receiver Data Bar, Differential PECL, AC coupled
13	+RX-DAT	1	Receiver Data, Differential PECL, AC coupled
14	R <sub>GND</sub>	1	Receiver Ground
15	V <sub>CC</sub> R	2	Receiver +5V Supply
16	V <sub>CC</sub> T	2	Transmitter +5V Supply
17	T <sub>GND</sub>	1	Transmitter Ground
18	+TX-DAT	1	Transmitter Data, Differential PECL, AC coupled
19	-TX-DAT	1	Transmitter Data Bar, Differential PECL, AC coupled
20	T <sub>GND</sub>	1	Transmitter Ground

A sequence value of 1 indicates that the signal is in the first group to engage during plugging of a module. A sequence value of 2 indicates that the signal is the second and last group. The two guide pins on the connector are electrically connected to the transceiver circuit ground. These two guide pins make contact with circuit prior to sequence 1 signals.

### Module Definition

Module Definition	MOD-DEF(0) PIN 4	MOD-DEF (1) PIN 5	MOD-DEF (2) PIN 6	Interpretation by Host
4	TTL Low	SCL	SDA	Serial module definition protocol

Module Definition 4 specifies a serial definition protocol. For this definition, upon power up, MOD-DEF(1:2) appear as no connector (NC) and MOD-DEF(0) is TTL LOW. When the host system detects this condition, it activates the serial protocol. The protocol uses the 2-wire serial CMOS E<sup>2</sup>PROM protocol of the ATMEL AT24C01A/02/04 family of components.

PACKAGE DIAGRAM

Units in mm

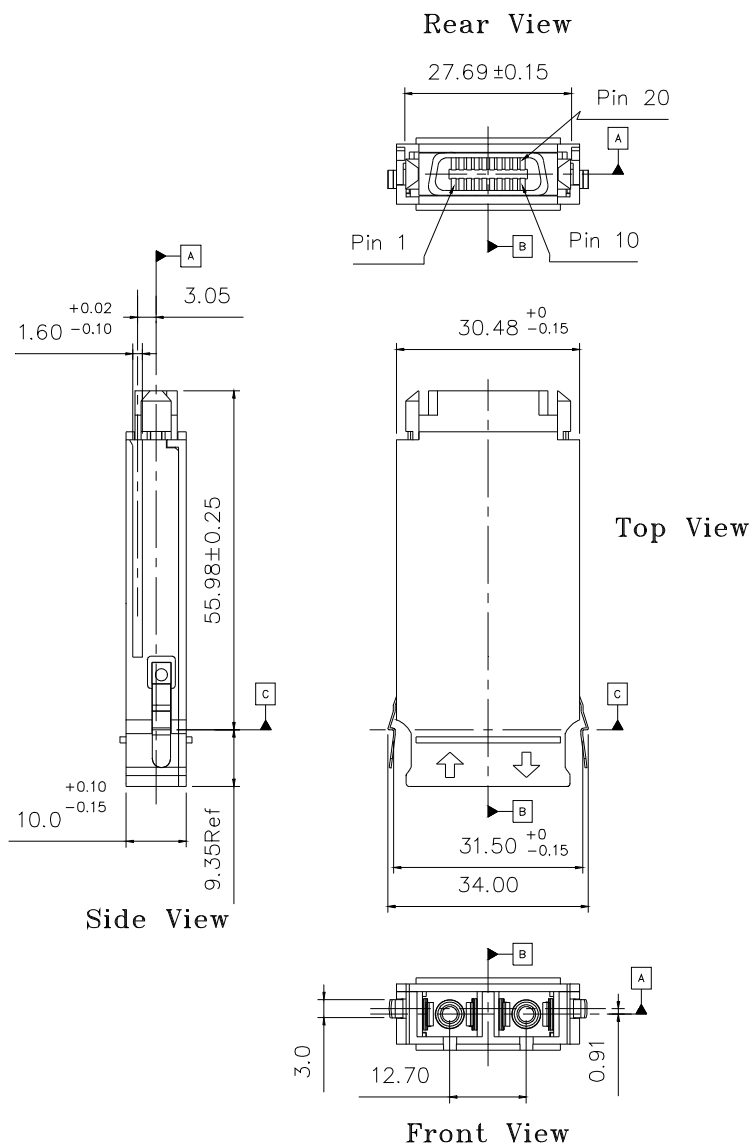

**Note:** Specifications subject to change without notice.