

QPM-2500WG

(RoHS Compliant)

100Gb/s / 850nm QSFP28 MPO Multi-Mode Optical Transceiver for QSFP28-SR4

FEATURES

- Up to 25.78125 Gbps Bi-directional Data Links Per Lane
- Compliant with SFF-8636
- Compliant with QSFP28 MSA
- Compliant with IEEE 802.3bm 100GBASE-SR4
- Hot Pluggable Electrical Interface
- Link Length up to 70 m with OM3 MMF
- Link Length up to 100 m with OM4 MMF
- 850 nm VCSEL Transmitter
- 2-Wire Interface for Integrated Digital Diagnostic Monitoring
- Maximum Power Dissipation < 2.0W
- Single +3.3V Power Supply
- RoHS Compliant
- 0 to 70°C Operating Case Temperature
- MPO optical connector

APPLICATIONS

- 100GBASE-SR4 Ethernet

DESCRIPTION

QPM-2500WG series multi-mode QSFP28 transceiver is designed for serial optical data communications such as 100GBASE-SR4. It supports the 100Gbps transmission on both OM3 and OM4 MMF. It is with the QSFP28 38-pin connector to allow hot plug capability. Digital diagnostic functions are available via an I2C. This module is designed for multi-mode fiber and operates at a nominal wavelength of 850 nm. The transmitter section uses four Vertical Cavity Surface Emitted Lasers (VCSEL). The receiver section uses four integrated GaAs detector preamplifiers (IDPs) and four limiting post-amplifier ICs.

A serial EEPROM in the transceiver allows the user to access transceiver digital diagnostic monitoring and configuration data via the 2-wire QSFP28 Management Interface. This interface uses a single address, A0h, with a memory map divided into a lower and upper area. Basic digital diagnostic data is held in the lower area while specific data is held in a series of tables in the high memory area.

LASER SAFETY

This multi-mode transceiver is a Class 1 laser product. It complies with IEC-60825-1 and FDA 21 CFR 1040.10 and 1040.11. The transceiver must be operated within the specified temperature and voltage limits. The optical ports of the module shall be terminated with an optical connector or with a dust plug.

ORDER INFORMATION

P/No.	Bit Rate per lane (Gb/s)	Distance (m)	Wavelength (nm)	Package	Connector	Temp (°C)	RoHS Compliant
QPM-2500WG	25.78125	70/100*	850	QSFP28 with DMI	MPO	0 to 70	Yes

*: 70 m for OM3 MMF, and 100 m for OM4 MMF.

Absolute Maximum Ratings					
Parameter	Symbol	Min	Max	Units	Notes
Storage Temperature	Tstg	-40	85	°C	
Operating Case Temperature	Topr	0	70	°C	
Relative Humidity	RH	5	95	%	Non condensing
Power Supply Voltage	V _{CC}	-0.3	4.0	V	

Recommended Operating Conditions					
Parameter	Symbol	Min	Typ	Max	Units / Notes
Power Supply Voltage	V _{CC}	3.14	3.3	3.46	V
Power Dissipation	P _D			2	W
Operating Case Temperature	Topr	0		70	°C
Data Rate per Channel			25.78125		Gb/s

Transmitter Optical Specifications (Topr= 0 to 70°C, Vcc3 = 3.3V ±5%)						
Parameter	Symbol	Min	Typ	Max	Units	Notes
Average Launch Power, each lane	$P_{O, Avg}$	-8.4		2.4	dBm	1
Extinction Ratio	ER	2			dB	
Center Wavelength	λ_c	840		860	nm	
Spectral Width (RMS)	s			0.6	nm	
Optical Eye Mask	Compliant with IEEE 802.3bm 100GBASE-SR4					
Optical Return Loss Tolerance				12	dB	

Receiver Optical Specifications (Topr= 0 to 70°C, Vcc3 = 3.3V ±5%)						
Parameter	Symbol	Min	Typ	Max	Units	Notes
Average Received Power, each lane		-10.3		2.4	dBm	
RX Sensitivity, each lane	Sen.		---	-10.3	dBm	
Receiver Wavelength	λ	840		860	nm	
Damage Threshold	Pmax	3.4	---		dBm	
LOS -- Deasserted	LOS_D	---	---	-12	dBm	Transition: low to high
LOS -- Asserted	LOS_A	-30	---	---	dBm	Transition: high to low
LOS -- Hysteresis		0.5	---		dB	

Electrical Characteristics						
Parameter	Symbol	Min	Typ	Max	Units	Notes
High-Speed Signal (CML) Interface Specification						
Differential Input Impedance	R_{in}	80	100	120	Ω	
Differential Data Input Amplitude		150		1050	mVpp	Internally AC coupled
Differential Data Output Amplitude		200		1100	mVpp	Internally AC coupled
Low-Speed Signal (LVTTTL) Interface Specification						
Input High Voltage		2.0		$V_{cc}+0.3$	V	
Input Low Voltage		-0.3		0.8	V	
Output High Voltage		$V_{cc}-0.5$		$V_{cc}+0.3$	V	
Output Low Voltage		0		0.4	V	

CONNECTION DIAGRAM

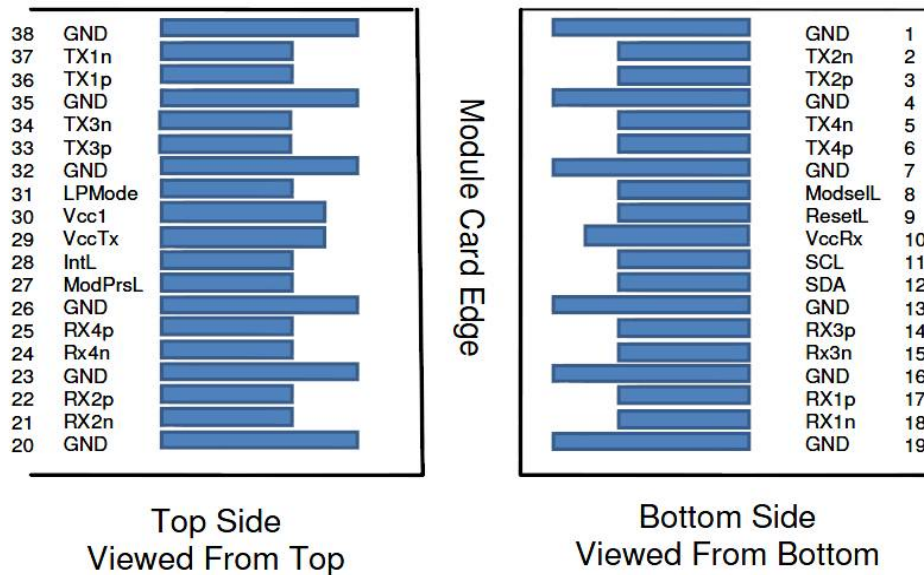

Table 3 PIN Description

PIN	Logic	Signal Name	Description	Note
1		GND	Ground	1
2	CML-I	Tx2n	Transmitter Inverted Data Input	
3	CML-I	Tx2p	Transmitter Non-Inverted Data Input	
4		GND	Ground	1
5	CML-I	Tx4n	Transmitter Inverted Data Input	
6	CML-I	Tx4p	Transmitter Non-Inverted Data Input	
7		GND	Ground	1
8	LVTTL-I	ModSelL	Module Select	
9	LVTTL-I	ResetL	Module Reset	
10		Vcc Rx	+3.3V Power Supply Receiver	2
11	LVC MOS-I/O	SCL	2-wire serial interface clock	
12	LVC MOS-I/O	SDA	2-wire serial interface data	
13		GND	Ground	1
14	CML-O	Rx3p	Receiver Non-Inverted Data Output	
15	CML-O	Rx3n	Receiver Inverted Data Output	
16		GND	Ground	1
17	CML-O	Rx1p	Receiver Non-Inverted Data Output	
18	CML-O	Rx1n	Receiver Inverted Data Output	
19		GND	Ground	1
20		GND	Ground	1
21	CML-O	Rx2n	Receiver Inverted Data Output	
22	CML-O	Rx2p	Receiver Non-Inverted Data Output	
23		GND	Ground	1
24	CML-O	Rx4n	Receiver Inverted Data Output	
25	CML-O	Rx4p	Receiver Non-Inverted Data Output	
26		GND	Ground	1
27	LVTTL-O	ModPrsL	Module Present	
28	LVTTL-O	IntL	Interrupt	
29		Vcc Tx	+3.3V Power supply transmitter	2
30		Vcc1	+3.3V Power supply	2
31	LVTTL-I	LPMode	Low Power Mode	
32		GND	Ground	1

33	CML-I	Tx3p	Transmitter Non-Inverted Data Input	
34	CML-I	Tx3n	Transmitter Inverted Data Input	
35		GND	Ground	1
36	CML-I	Tx1p	Transmitter Non-Inverted Data Input	
37	CML-I	Tx1n	Transmitter Inverted Data Input	
38		GND	Ground	1

1. Module ground pins GND are isolated from the module case and chassis ground within the module.
2. Vcc Rx, Vcc1 and Vcc Tx are the receiver and transmitter power supplies and shall be applied concurrently. Vcc Rx Vcc1 and Vcc Tx may be internally connected within the QSFP28 module in any combination. The connector pins are each rated for a maximum current of 500 mA.

MECHANICAL SPECIFICATION (UNITS IN MM)

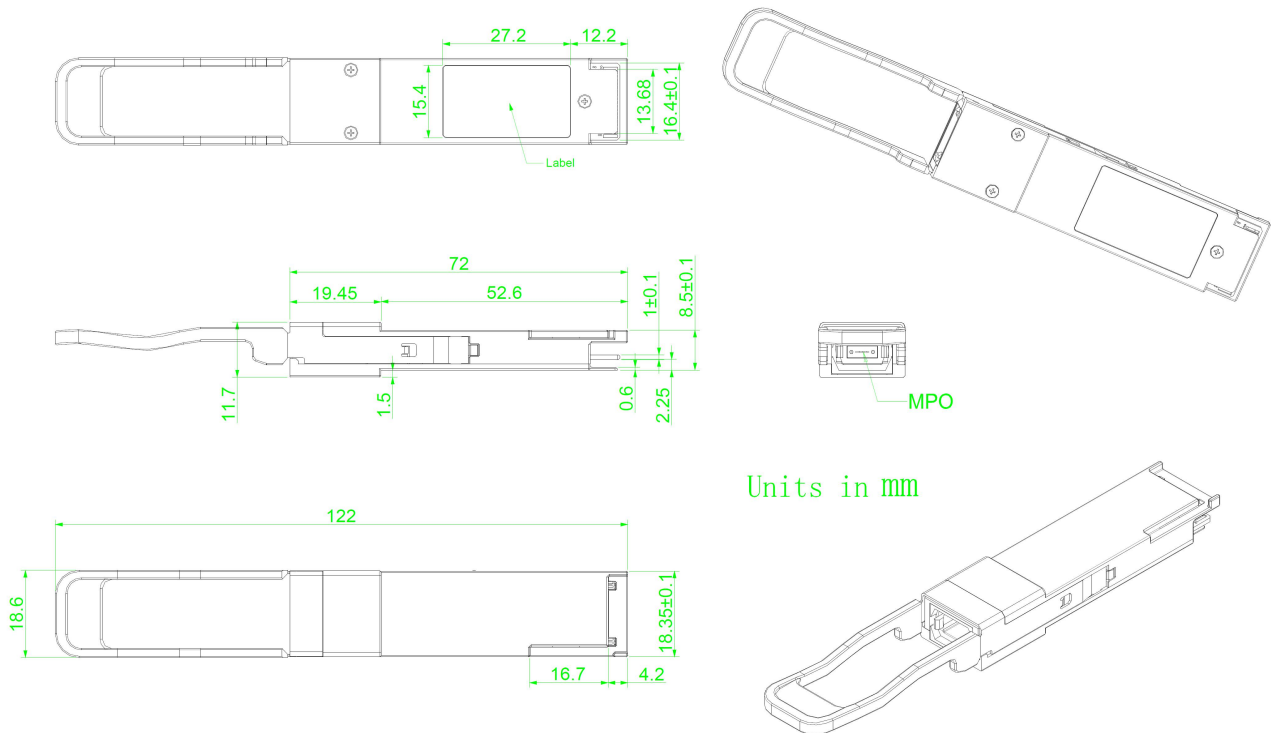

RECOMMENDED INTERFACE CIRCUIT

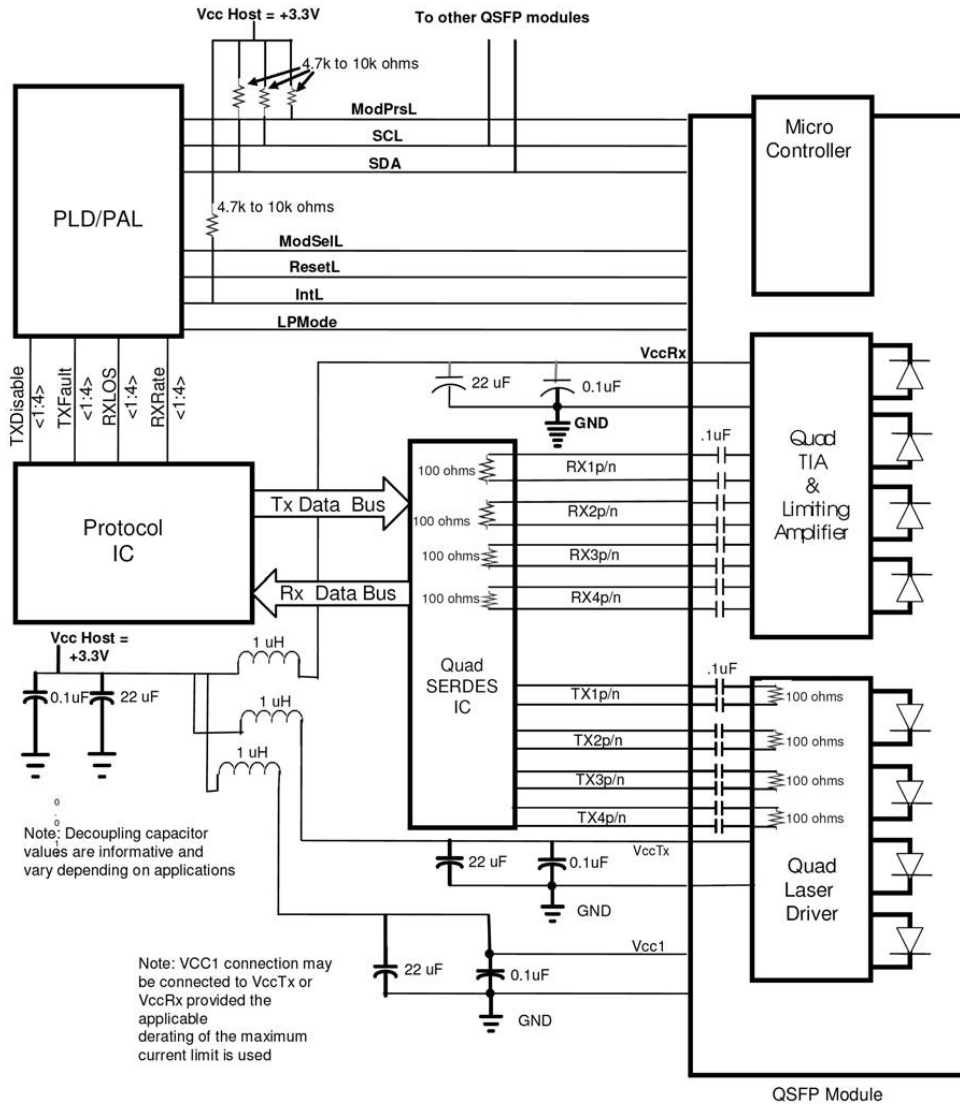

REVISION HISTORY

Version	Subject	Release Date
1.0	Initial datasheet	2019/4/16