

QPS-5140PW-OXXG

(RoHS Compliant)

100GE / 40km / 200GHz DWDM QSFP28 LC SINGLE-MODE Optical Transceiver

FEATURES

- Up to 106.25 Gbps Bi-directional Data Links Per Lane
- Compliant with QSFP28 MSA
- Compliant with 100G Lambda MSA 100G-ER1-40 Specification
- Hot Pluggable Electrical Interface
- Link Length up to 40km with SMF
- Cooled DWDM EML Transmitter
- 200 GHz Grid, O Band defined in the CW-WDM MSA
- 2-Wire Interface for Integrated Digital Diagnostic Monitoring
- Power Consumption < 5W
- Single +3.3V Power Supply
- RoHS Compliant
- 0 to 70°C Case Temp Operation
- Duplex LC Connector
- Class 1 Laser International Safety Standard IEC-60825 Compliant

APPLICATIONS

- 100G Lambda MSA 100G-ER1-40
- 100GBASE Ethernet

DESCRIPTION

QPS-5140PW-OXXG series single mode QSFP28 transceiver is designed for single-mode fiber optical data communications such as 100G Lambda MSA 100G-ER1-40.

The transceiver consists of two sections: The transmitter section consists of a cooled DWDM EML and is a class 1 laser compliant according to International Safety Standard IEC-60825. The receiver section uses an integrated avalanche photo detector preamplifier mounted in an optical header.

The module is with the QSFP28 38-pin connector to allow hot plug capability. The internally ac coupled high speed serial I/O simplifies interfacing to external circuitry. Only single 3.3V power supply is needed.

A serial EEPROM in the transceiver allows the user to access transceiver digital diagnostic monitoring and configuration data via the 2-wire QSFP28 Management Interface. This interface uses a single address, A0h, with a memory map divided into a lower and upper area. Basic digital diagnostic data is held in the lower area while specific data is held in a series of tables in the high memory area.

LASER SAFETY

This single mode transceiver is a Class 1 laser product. It complies with IEC-60825-1 and FDA 21 CFR 1040.10 and 1040.11. The transceiver must be operated within the specified temperature and voltage limits. The optical ports of the module shall be terminated with an optical connector or with a dust plug.

ORDER INFORMATION

P/No.	Bit Rate (Gb/s)	Distance (km)	Spacing (GHz)	Wavelength (nm)	Package	Case Temp (°C)	RoHS Compliant
QPS-5140PW-OXXG	106.25	40	200	DWDM*	QSFP28 with DMI	0 to 70	Yes

*: XX: 200 GHz Grid, O Band defined in the CW-WDM MSA (Please see below)

Channel #	Product code	Frequency (THz)	Center Wavelength (nm)	Label
98	QPS-5140PW-O98G	229.8	1304.58	O98
96	QPS-5140PW-O96G	229.6	1305.72	O96
94	QPS-5140PW-O94G	229.4	1306.85	O94
92	QPS-5140PW-O92G	229.2	1308.00	O92
90	QPS-5140PW-O90G	229.0	1309.14	O90
88	QPS-5140PW-O88G	228.8	1310.28	O88
86	QPS-5140PW-O86G	228.6	1311.43	O86
84	QPS-5140PW-O84G	228.4	1312.58	O84

Absolute Maximum Ratings					
Parameter	Symbol	Min	Max	Units	Notes
Storage Temperature	Tstg	-40	85	°C	
Operating Case Temperature	Topr	0	70	°C	
Relative Humidity	RH	0	85	%	Non condensing

Recommended Operating Conditions					
Parameter	Symbol	Min	Typ	Max	Units / Notes
Power Supply Voltage	V _{CC}	3.135	3.3	3.465	V
Power Supply Current	I _{CC}			1443	mA
Power Dissipation	P _D			5	W
Operating Case Temperature	Topr	0		70	°C
PAM4 Singling Rate			53.125		GBd / ± 100 ppm

Transmitter Optical Specifications (Vcc3 = 3.3V ±5%)						
Parameter	Symbol	Min	Typ	Max	Units	Notes
Output Center Wavelength	λ_c	X-0.1	X	X+0.1	nm	1
	fc	Y-18	Y	Y+18	GHz	1
Side Mode Suppression Ratio	SMSR	30			dB	
Average Launch Power	Po, Avg	1.7		7.1	dBm	2
Outer OMA	OMA _{outer}	4.7		7.9	dBm	
Launch power in OMA _{outer} minus TDECQ		3.3			dBm	
Transmitter and dispersion penalty eye closure for PAM4	TDECQ			3.9	dB	
Transmitter over/under-shoot				22	%	
Transmitter power excursion				3.9	dBm	
Extinction Ratio	ER	5			dB	
Transmitter transition time				17	ps	
Average Launch Power of OFF Transmitter				-15	dBm	
RIN _x OMA				-136	dB/Hz	
Optical return loss tolerance				15	dB	
Transmitter reflectance				-26	dB	3

1. X, Y = specified 200 GHz Grid, O Band defined in the CW-WDM MSA
2. Average launch power, each lane min is informative and not the principal indicator of signal strength. A transmitter with launch power below this value cannot be compliant; however, a value above this does not ensure compliance.
3. Transmitter reflectance is defined looking into the transmitter.

Receiver Optical Specifications (Vcc3 = 3.3V ±5%)						
Parameter	Symbol	Min	Typ	Max	Units	Notes
Wavelength of Operation		1304.5		1317.5		
Damage Threshold		-2.4			dBm	4
Average receive power		-16.0		-3.4	dBm	5
Receiver power (OMA)	OMA _{outer}			-2.6	dBm	
Receiver reflectance				-26	dB	
Receiver sensitivity (OMA _{outer})	Sen			RS	dBm	RS= max (-13.8, TECQ-15.2)
LOS Assert	Pa	-35			dBm	
LOS Deassert	Pd			-16	dBm	
LOS Hysteresis		0.5			dB	

4. The receiver shall be able to tolerate, without damage, continuous exposure to an optical signal having this average power level. The receiver does not have to operate correctly at this input power.
5. Average receive power, (min) is informative and not the principal indicator of signal strength. A received power below this value cannot be compliant; however, a value above this does not ensure compliance.

CONNECTION DIAGRAM

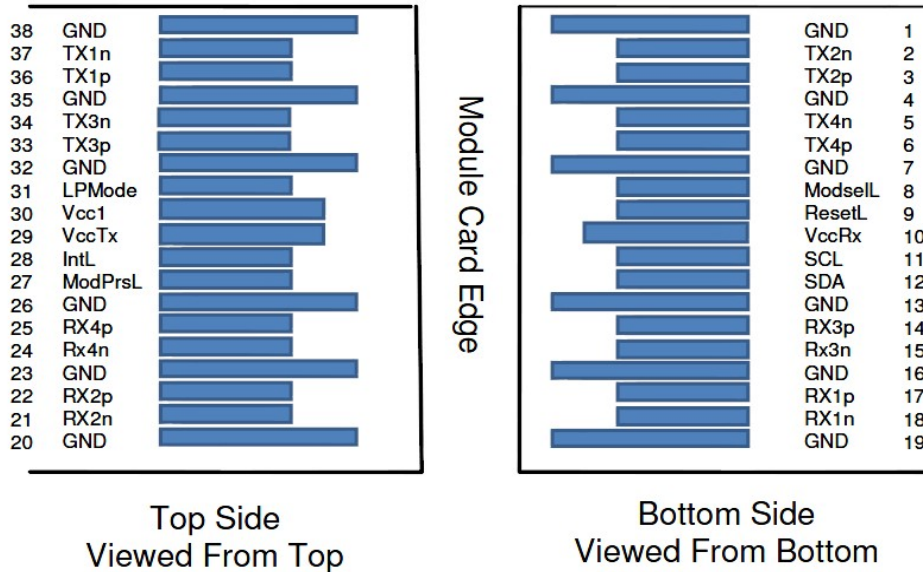

Table 3 PIN Description

PIN	Logic	Signal Name	Description	Note
1		GND	Ground	1
2	CML-I	Tx2n	Transmitter Inverted Data Input	
3	CML-I	Tx2p	Transmitter Non-Inverted Data Input	
4		GND	Ground	1
5	CML-I	Tx4n	Transmitter Inverted Data Input	
6	CML-I	Tx4p	Transmitter Non-Inverted Data Input	
7		GND	Ground	1
8	LVTTL-I	ModSelL	Module Select	
9	LVTTL-I	ResetL	Module Reset	
10		Vcc Rx	+3.3V Power Supply Receiver	2
11	LVC MOS-I/O	SCL	2-wire serial interface clock	
12	LVC MOS-I/O	SDA	2-wire serial interface data	
13		GND	Ground	1
14	CML-O	Rx3p	Receiver Non-Inverted Data Output	
15	CML-O	Rx3n	Receiver Inverted Data Output	
16		GND	Ground	1
17	CML-O	Rx1p	Receiver Non-Inverted Data Output	
18	CML-O	Rx1n	Receiver Inverted Data Output	
19		GND	Ground	1
20		GND	Ground	1
21	CML-O	Rx2n	Receiver Inverted Data Output	
22	CML-O	Rx2p	Receiver Non-Inverted Data Output	
23		GND	Ground	1
24	CML-O	Rx4n	Receiver Inverted Data Output	
25	CML-O	Rx4p	Receiver Non-Inverted Data Output	
26		GND	Ground	1
27	LVTTL-O	ModPrsL	Module Present	
28	LVTTL-O	IntL	Interrupt	
29		Vcc Tx	+3.3V Power supply transmitter	2
30		Vcc1	+3.3V Power supply	2
31	LVTTL-I	LPMode	Low Power Mode	
32		GND	Ground	1

33	CML-I	Tx3p	Transmitter Non-Inverted Data Input	
34	CML-I	Tx3n	Transmitter Inverted Data Input	
35		GND	Ground	1
36	CML-I	Tx1p	Transmitter Non-Inverted Data Input	
37	CML-I	Tx1n	Transmitter Inverted Data Input	
38		GND	Ground	1

1. Module ground pins GND are isolated from the module case and chassis ground within the module.
2. Vcc Rx, Vcc1 and Vcc Tx are the receiver and transmitter power supplies and shall be applied concurrently. Vcc Rx Vcc1 and Vcc Tx may be internally connected within the QSFP28 module in any combination.

MECHANICAL SPECIFICATION (UNITS IN MM)

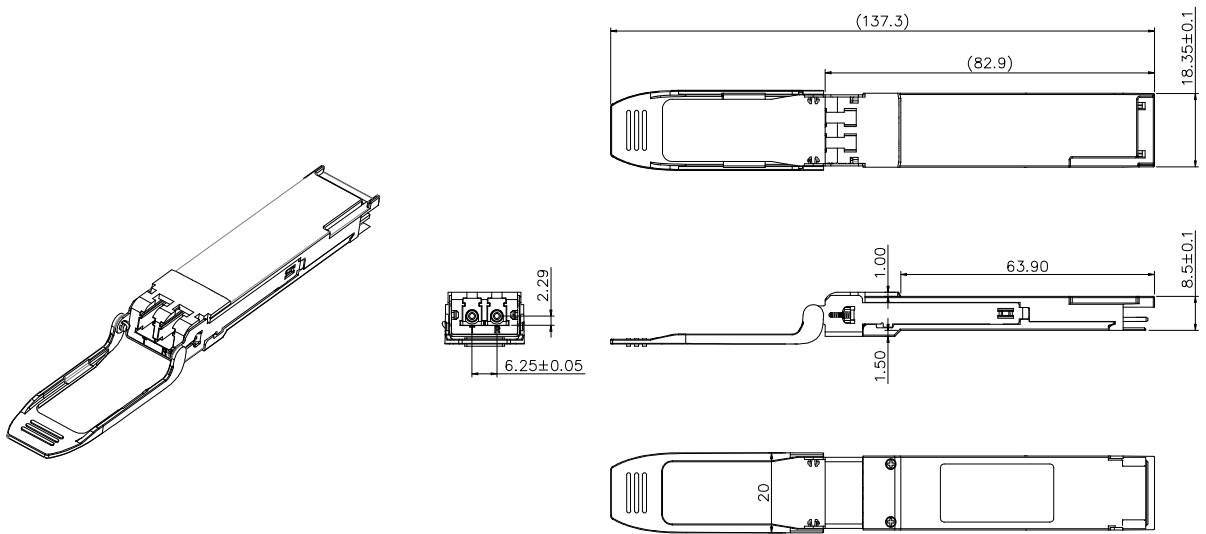

Note: Specifications subject to change without notice.

REVISION HISTORY

Version	Subject	Release Date
1.0	Initial datasheet	2023/10/16