

SPM-9100FG / SPM-9100AFG

(RoHS Compliant)

3.3V / 850 nm / 2.125 Gbps SFP LC MULTI-MODE TRANSCEIVER

FEATURES

- Hot-Pluggable SFP Footprint LC Optical Transceiver
- Small Form-Factor Pluggable (SFP) MSA compatible
- Compliant with Fiber Channel FC-PH-2 for 200-M5-SN-1 and 200-M6-SN-1
- Compliant with IEEE 802.3z Gigabit Ethernet 1000BASE-SX
- Link Distance at 2.125 Gbd
150 m links with 62.5/125 μm MMF Cables
300 m links with 50/125 μm MMF Cables
- Link Distance at 1.026 Gbd
300 m links with 62.5/125 μm MMF Cables
500 m links with 50/125 μm MMF Cables
- AC/AC Coupling according to MSA
- Single +3.3 V Power Supply
- RoHS Compliant
- -10 to 85°C Operation: SPM-9100FG
- -40 to 85°C Operation: SPM-9100AFG
- Class 1 Laser International Safety Standard IEC 60825 Compliant

DESCRIPTION

The SPM-9100FG series multi-mode transceivers are small form factor pluggable module for bi-directional serial optical data communications such as Gigabit Ethernet 1000BASE-SX and Fiber Channel FC-PH-2 for 200-M5-SN-1 and 200-M6-SN-1. It is with the SFP 20-pin connector to allow hot plug capability. This module is designed for multi-mode fiber and operates at a nominal wavelength of 850 nm. The transmitter section uses a Vertical Cavity Surface Emitted Laser (VCSEL) and is a Class 1 laser compliant according to International Safety Standard IEC 60825. The receiver section uses an integrated GaAs detector preamplifier (IDP) mounted in an optical header and a limiting post-amplifier IC.

LASER SAFETY

This multi-mode transceiver is a Class 1 laser product. It complies with IEC 60825 and FDA 21 CFR 1040.10 and 1040.11. The transceiver must be operated within the specified temperature and voltage limits. The optical ports of the module shall be terminated with an optical connector or with a dust plug.

APPLICATIONS

- Gigabit Ethernet Switches and Routers
- Fiber Channel Switch Infrastructure
- XDSL Applications

ORDER INFORMATION

P/No.	Bit Rate (Gb/s)	FC-PI	Distance (m)	Wavelength (nm)	Package	Temp. (°C)	TX Power (dBm)	RX Sens. (dBm)	RoHS Compliant
SPM-9100FG	2.125/1.063	200/100	150/300**	850	LC SFP	-10 to 85	-2.5 to -9	-15	Yes
SPM-9100AFG	2.125/1.063	200/100	150/300**	850	LC SFP	-40 to 85	-2.5 to -9	-15	Yes

*: 150 meter for 62.5/125 μm MM fiber; 300 meter for 50/125 μm MM Fiber.

Absolute Maximum Ratings					
Parameter	Symbol	Min	Max	Units	Notes
Storage Temperature	Tstg	-40	85	°C	
Operating Case Temperature	Topr	-10	85	°C	SPM-9100FG
		-40	85		SPM-9100AFG
Power Supply Voltage	Vcc	-0.5	3.6	V	

Recommended Operating Conditions					
Parameter	Symbol	Min	Typ	Max	Units / Notes
Power Supply Voltage	Vcc	3.1	3.3	3.5	V
Case Operating Temperature	Topr	-10		85	°C / SPM-9100FG
		-40		85	°C / SPM-9100AFG
Power Supply Current	I _{CC(TX+RX)}			250	mA
Data Rate		1000	2125		Mb/s

OPTOWAY TECHNOLOGY INC. No.38, Kuang Fu S. Road, Hu Kou, Hsin Chu Industrial Park, Hsin Chu, Taiwan 303

Tel: 886-3-5979798

Fax: 886-3-5979737

E-mail: sales@optoway.com

http://www.optoway.com

1/1/2008 V2.0

Transmitter Specifications (-10°C < Topr < 85°C, 3.1V < Vcc < 3.5V)						
Parameter	Symbol	Min	Typ	Max	Units	Notes
Optical						
Optical Transmit Power	Po	-9	---	-2.5	dBm	1
Output Center Wavelength	λ	830		860	nm	
Output Spectrum Width	$\Delta\lambda$	---	---	0.85	nm	RMS (σ)
Optical Modulation Amplitude	OMA	196			μ W	2
Extinction Ratio	ER		9	---	dB	
Optical Rise Time	t_r			160	ps	20 % to 80% Values
Optical Fall Time	t_f			160	ps	20 % to 80% Values
Relative Intensity Noise	RIN			-120	dB/Hz	
Electrical						
Data Input Current – Low	I _{IL}	-350			μ A	
Data Input Current – High	I _{IH}			350	μ A	
Differential Input Voltage	V _{IH} - V _{IL}	0.5		2.4	V	Peak-to-Peak
TX Disable Input Voltage – Low	T _{DIS.L}	0		0.5	V	3
TX Disable Input Voltage – High	T _{DIS.H}	2.0		Vcc	V	3
TX Disable Assert Time	T _{ASSERT}			10	μ s	
TX Disable Deassert Time	T _{DEASSERT}			1	ms	
TX Fault Output Voltage -- Low	T _{FaultL}	0		0.5	V	4
TX Fault Output Voltage -- High	T _{FaultH}	2.0		Vcc+0.3	V	4

1. Output power is power coupled into a 62.5/125 μ m MM fiber.
2. An OMA of 196 μ W is approximately equal to an average power of -9 dBm assuming an Extinction Ratio of 9 dB.
3. There is an internal 4.7K to 10K ohm pull-up resistor to VccTX.
4. Open collector compatible, 4.7K to 10K ohm pull-up to Vcc (Host Supply Voltage).

Receiver Specifications (-10°C < Topr < 85°C, 3.1V < Vcc < 3.5V)						
Parameter	Symbol	Min	Typ	Max	Units	Notes
Optical						
Optical Modulation Amplitude	Sens	40			μ W	5
Stress RX Sens		96			μ W	FC-PI Std.
Maximum Input Power	Pin	-3	0		dBm	
Signal Detect -- Asserted	Pa	---		-16	dBm	Transition: low to high
Signal Detect -- Deasserted	Pd	-30	---	---	dBm	Transition: high to low
Signal detect -- Hysteresis		1.0	---		dB	
Wavelength of Operation		700	---	900	nm	
Electrical						
Differential Output Voltage	V _{OH} - V _{OL}	0.6		2.0	V	
Output LOS Voltage -- Low	V _{OL}	0		0.8	V	6
Output LOS Voltage -- High	V _{OH}	2.0		Vcc+0.3	V	6

5. An OMA of 40 μ W is approximately equal to an average power of -17 dBm assuming an extinction ratio of 9 dB.
6. Open collector compatible, 4.7K to 10K ohm pull-up to Vcc (Host Supply Voltage).

CONNECTION DIAGRAM

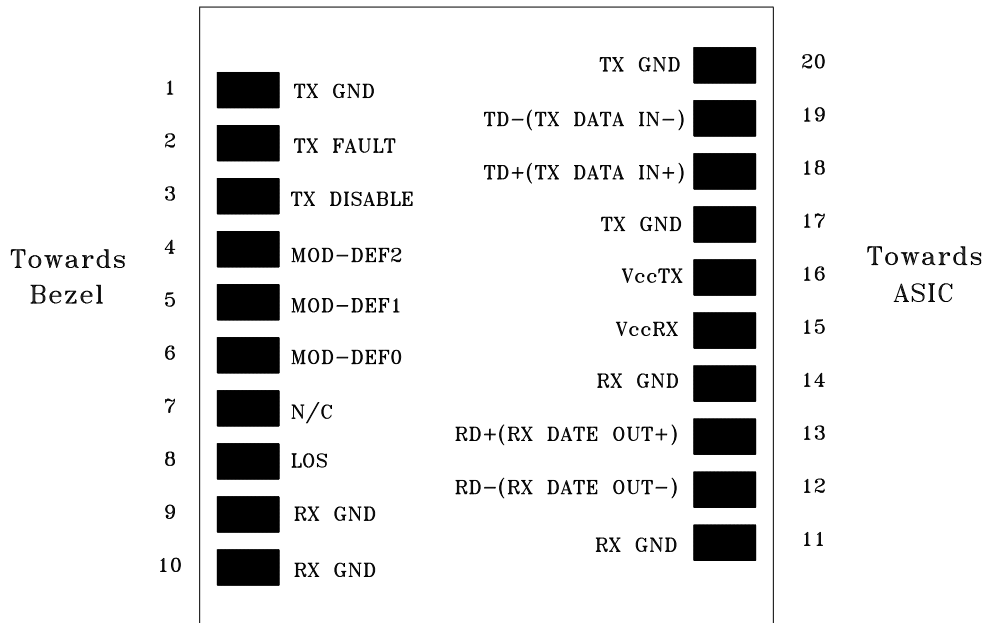

PIN	Signal Name	Description	PIN	Signal Name	Description
1	TX GND	Transmitter Ground	11	RX GND	Receiver Ground
2	TX Fault	Transmitter Fault Indication	12	RX DATA OUT-	Inverse Receiver Data Out
3	TX Disable	Transmitter Disable (Module disables on high or open)	13	RX DATA OUT+	Receiver Data Out
4	MOD-DFE2	Modulation Definition 2 – Two wires serial ID Interface	14	RX GND	Receiver Ground
5	MOD-DEF1	Modulation Definition 1 – Two wires serial ID Interface	15	Vcc RX	Receiver Power – 3.3V±5%
6	MOD-DEF0	Modulation Definition 0 – Ground in Module	16	Vcc TX	Transmitter Power – 3.3V±5%
7	N/C	Not Connected	17	TX GND	Transmitter Ground
8	LOS	Loss of Signal	18	TX DATA IN+	Transmitter Data In
9	RX GND	Receiver Ground	19	TX DATA IN-	Inverse Transmitter Data In
10	RX GND	Receiver Ground	20	TX GND	Transmitter Ground

Module Definition

Module Definition	MOD-DEF2 PIN 4	MOD-DEF1 PIN 5	MOD-DEF0 PIN 6	Interpretation by Host
4	SDA	SCL	LV-TTL Low	Serial module definition protocol

Module Definition 4 specifies a serial definition protocol. For this definition, upon power up, MOD-DEF(1:2) appear as no connector (NC) and MOD-DEF(0) is TTL LOW. When the host system detects this condition, it activates the serial protocol. The protocol uses the 2-wire serial CMOS E²PROM protocol of the ATMEL AT24C01A/02/04 family of components.

RECOMMENDED CIRCUIT SCHEMATIC

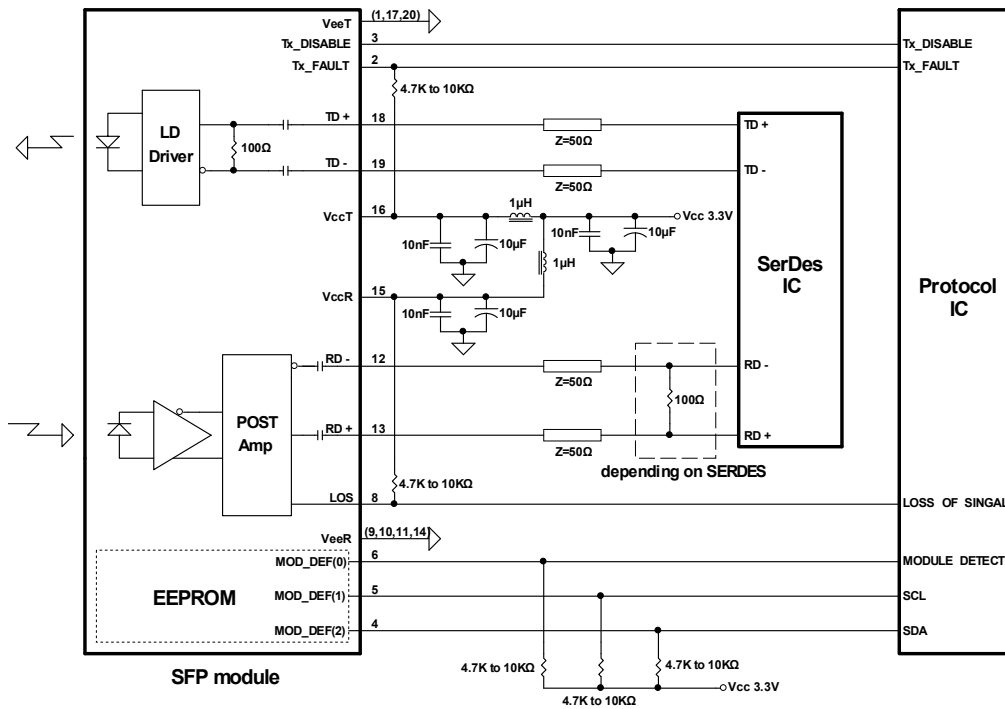

PACKAGE DIAGRAM

Units in mm

Top View

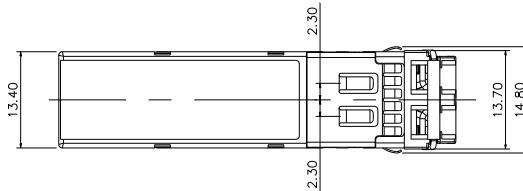

Front View

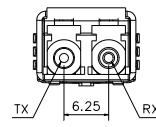
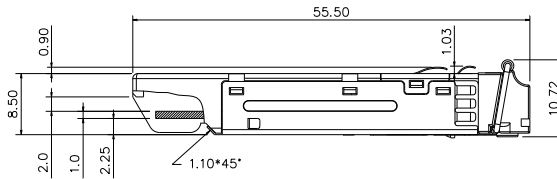

Side View

Bottom View

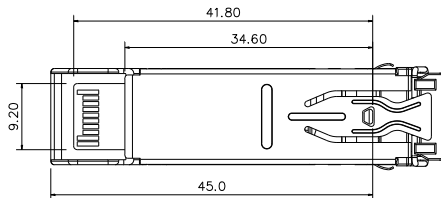

Note: Specifications subject to change without notice.

Revision History

Version	Subject	Release Date
1.0	Initial datasheet	2005/12/1
2.0	Revise package diagram for high port density use	2008/1/1