

**SPM-9100VW-2TG / SPM-9100AVW-2TG**

**(RoHS Compliant)**

**3 Gb/s / 850 nm Dual Optical Multi-Mode Transmitter**

**FEATURES**

- SMPTE 297-2006 Compatible
- Speed from 50 Mbps to 3Gbps with up to 1000 m Multi-mode Fiber
- Distance up to 300 m for 3G-SDI
- Support Video Pathological Patterns for SD-SDI, HD-SDI and 3G-SDI
- Dual 850 nm Transmitter with Duplex LC
- Based on Industry Standard SFP
- SFF-8472 Digital Diagnostic Function
- Two Independent TTL Laser Disable Input
- Single +3.3 V Power Supply
- RoHS Compliant
- 0 to 70°C Operation: SPM-9100VW-2TG
- -40 to 85°C Operation: SPM-9100AVW-2TG
- Hot Pluggable
- Class 1 Laser International Safety Standard IEC-60825 Compliant

**APPLICATIONS**

- SMPTE 297-2006 Compliant Electrical-to-Optical Interfaces
- High-density Video Routers

**DESCRIPTION**

The SPM-9100VW-2TG is a dual channel optical multi-mode transmitter module designed to transmit optical serial digital signals as defined in SMPTE 297-2006. It supports from 50 Mbps to 3Gbps and is specifically designed for transmitted the SMPTE 259M, SMPTE 344M and SMPTE 292M and SMPTE 424M SDI pathological patterns. It is with the SFP 20-pin connector to allow hot plug capability. Digital diagnostic functions are available via an I<sup>2</sup>C. It is with two independent 850 nm VCSEL transmitters. Each transmitter can transmit signal from 50 Mbps to 3Gbps with up to 1000 m of multi-mode fiber when using the SPM-9100VW-2RG as the receiver. A maximum distance of 300 m is achievable with 3Gbps pathological signals.

**LASER SAFETY**

This multi-mode transceiver is a Class 1 laser product. It complies with IEC-60825 and FDA 21 CFR 1040.10 and 1040.11. The transceiver must be operated within the specified temperature and voltage limits. The optical ports of the module shall be terminated with an optical connector or with a dust plug.

**ORDER INFORMATION**

P/No.	Type	Bit Rate (Mb/s)	TX1		TX2		Package	Temp (°C)	RoHS Compliant
			λ (nm)	Power (dBm)	λ (nm)	Sen. (dBm)			
SPM-9100VW-2TG	2-TX	50 to 3000	850	-2 to -7	850	-2 to -7	LC SFP	0 to 70	Yes
SPM-9100AVW-2TG	2-TX	50 to 3000	850	-2 to -7	850	-2 to -7	LC SFP	-40 to 85	Yes

**RELATED PRODUCTS**

P/No.	Type	Bit Rate (Mb/s)	RX1		RX2		Package	Temp (°C)	RoHS Compliant
			λ (nm)	Power (dBm)	λ (nm)	Sen. (dBm)			
SPM-9100VW-2RG	2-RX	50 to 3000	850	0 to -15	850	0 to -15	LC SFP	0 to 70	Yes
SPM-9100AVW-2RG	2-RX	50 to 3000	850	0 to -15	850	0 to -15	LC SFP	-40 to 85	Yes

**LINK DISTANCE**

Transmitter	Receiver	SDI	Bit Rate	Max. Link Distance (m)
SPM-9100VW-2TG	SPM-9100VW-2RG	3G-SDI	2.97Gbps	300
		HD-SDI	1.485Gbps	500
		SD-SDI	270Mb/s	1,000
SPM-9100AVW-2TG	SPM-9100AVW-2RG	3G-SDI	2.97Gbps	300
		HD-SDI	1.485Gbps	500
		SD-SDI	270Mb/s	1,000

### Absolute Maximum Ratings

Exposure to absolute maximum rating conditions for extended periods may affect device reliability.

Absolute Maximum Ratings					
Parameter	Symbol	Min	Max	Units	Notes
Storage Temperature	Tstg	-40	85	°C	
Operating Case Temperature	Tc	0 -40	70 85	°C	SPM-9100VW-2TG SPM-9100AVW-2TG
Power Supply Voltage	Vcc	0	4	V	
ESD Tolerance on all pins			1	KV HBM	
Relative Humidity	---	5	95	% RH	non-condensing

Recommended Operating Conditions					
Parameter	Symbol	Min	Typ	Max	Units / Notes
Power Supply Voltage	Vcc	3.13	3.3	3.47	V
Operating Case Temperature	Tc	0 -40		70 85	°C / SPM-9100VW-2TG °C / SPM-9100AVW-2TG
Baud Rate		50		3000	Mb/s
Power Supply Current	Icc		125	180	mA

Transmitter Specifications (0°C < Tc < 70°C, 3.13V < Vcc < 3.47V)						
Parameter	Symbol	Min	Typ	Max	Units	Notes
<b>Optical</b>						
Average Launch Power	PO <sub>Avg</sub>	-7		-2	dBm	1
Output Center Wavelength	λ	830	850	870	nm	
Output Spectrum Width	Δλ	---		1	nm	RMS (σ)
Extinction Ratio	ER	5	7.5		dB	
Relative Intensity Noise	RIN			-118	dB/Hz	
Optical Rise Time / Fall Time	tr / tf			135	ps	2, SMPTE 424M
				270	ps	2, SMPTE 292M
				800	ps	2, SMPTE 344M
				1.5	ns	2, SMPTE 259M
<b>Electrical</b>						
Differential Input Voltage	V <sub>IH</sub> - V <sub>IL</sub>	200		1200	mVp-p	AC coupled input
Disable Input Voltage -- Low	V <sub>TDIS,L</sub>	0		0.8	V	TX Output Enabled
Disable Input Voltage -- High	V <sub>TDIS,H</sub>	2.0		Vcc+0.3	V	TX Output Disabled
SCL, SDA	V <sub>OH</sub>	2.5		Vcc+0.3	V	
	V <sub>OL</sub>	0		0.5	V	

- Output power is power coupled into a 50/125 μm multi-mode fiber.
- 20% to 80%, unfiltered.

### MODULE DEFINITION

Module Definition	PIN 5	PIN 6	Interpretation by Host
4	SCL	SDA	Serial module definition protocol

Module Definition 4 specifies a serial definition protocol. For this definition, upon power up, SCL and SDA appear as no connector (NC). When the host system detects this condition, it activates the serial protocol. The protocol uses the 2-wire serial CMOS E<sup>2</sup>PROM protocol of the ATMEL AT24C01A/02/04 family of components.

CONNECTION DIAGRAM

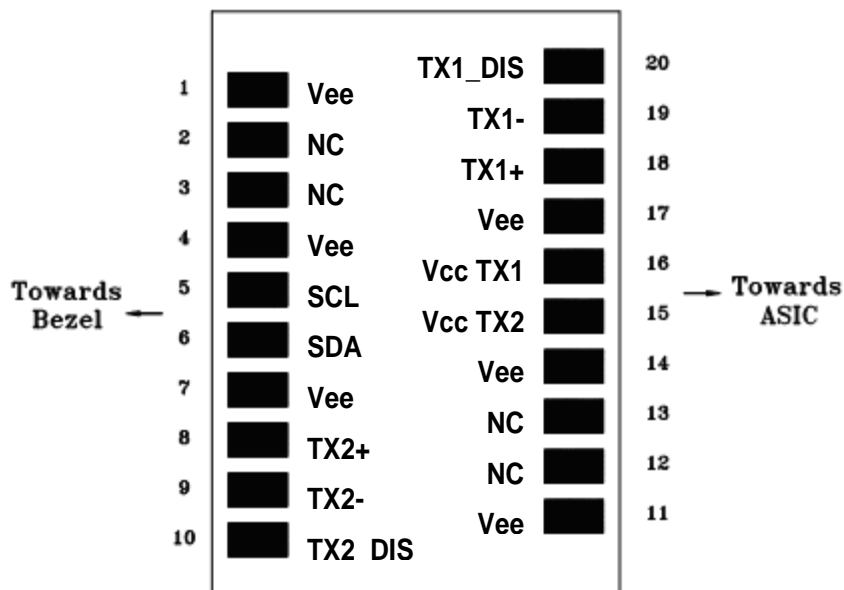

PIN	Name	Function	Notes
1	Vee	Signal Ground	
2	NC	No Connection	
3	NC	No Connection	
4	Vee	Signal Ground	
5	SCL	Serial I <sup>2</sup> C Clock	
6	SDA	Serial I <sup>2</sup> C Data	
7	Vee	Signal Ground	
8	TX2+	Positive Transmitter Data In (2)	AC coupled differential lines with 100 ohm differential termination inside the module
9	TX2-	Negative Transmitter Data In (2)	
10	TX2_DIS	Transmitter Disable (2)	Internal 4.7 kΩ pull-up. The bias current and modulation current are turned off if TX2_DIS = HIGH.
11	Vee	Signal Ground	
12	NC	No Connection	
13	NC	No Connection	
14	Vee	Signal Ground	
15	Vcc TX2	Power Supply (2)	+3.3V±5%
16	Vcc TX1	Power Supply (1)	
17	Vee	Signal Ground	
18	TX1+	Positive Transmitter Data In (1)	AC coupled differential lines with 100 ohm differential termination inside the module
19	TX1-	Negative Transmitter Data In (1)	
20	TX1_DIS	Transmitter Disable (1)	Internal 4.7 kΩ pull-up. The bias current and modulation current are turned off if TX1_DIS = HIGH.

## RECOMMENDED CIRCUIT SCHEMATIC

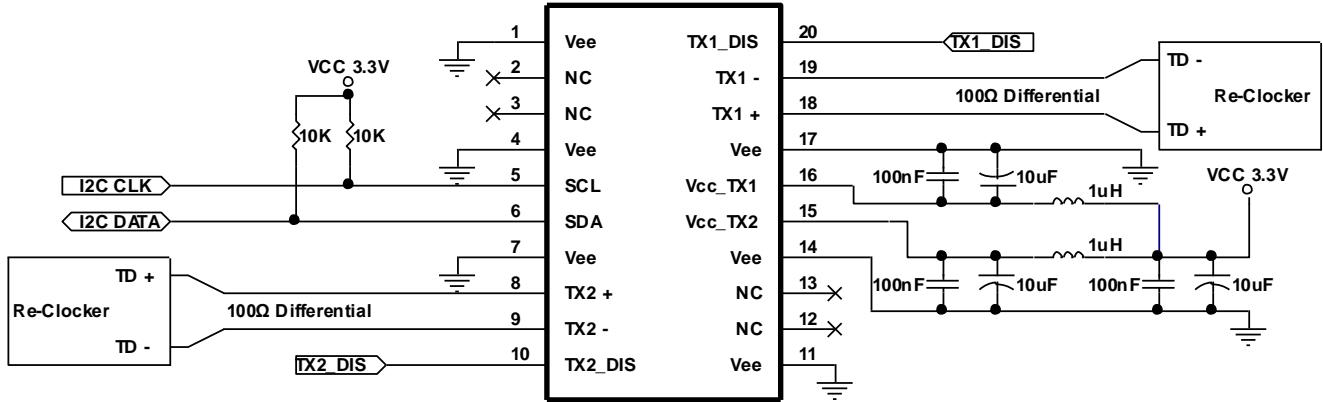

1. Consult the Chipset manufacturer’s applications information for biasing required for TX outputs. Some chipset outputs are internally biased and may not need external bias resistor.

## PACKAGE DIAGRAM (Units in mm)

Top View

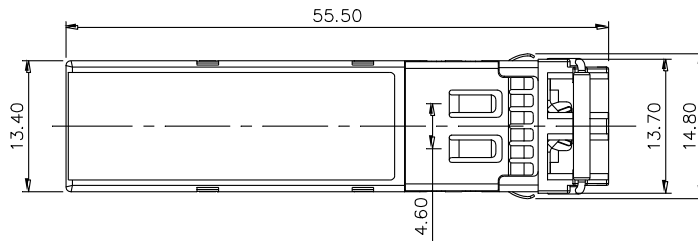

Front View

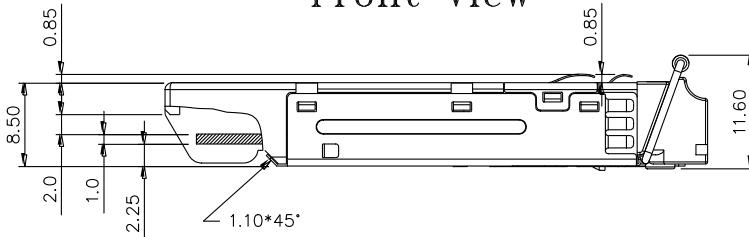

LATCH COLOR  
BLACK

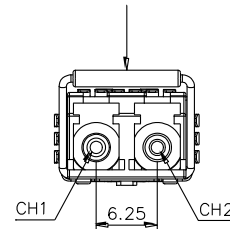

Side View

Bottom View

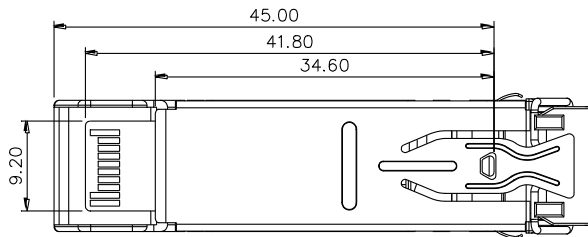

Note: Specifications subject to change without notice.

\*\*\*\*\*  
**REVISION HISTORY**

Version	Subject	Release Date
1.0	Initial datasheet	2008/11/1
2.0	Add SPM-9100AVW-2TG	2024/7/10