

### SPS-2380WG / SPS-2380BWG / SPS-2380AWG

(RoHS Compliant)

### 10.3 Gbps / 80km / 1550nm Digital Diagnostic LC SFP+ SINGLE-MODE TRANSCEIVER

#### FEATURES

- Support 9.95Gbps to 10.5 Gbps
- Compliant with SFP+ MSA
- Compliant to IEEE 802.3ae 10GBASE-ZR/ZW
- SFF-8472 Digital Diagnostic Function
- Temperature-stabilized 1550 nm EML Transmitter
- Distance up to 80 km at SM Fiber
- AC/AC Coupling according to MSA
- Single +3.3 V Power Supply
- Low Power Consumption
- RoHS Compliant
- 0 to 70°C Operating: SPS-2380WG
- -5 to 85°C Operating: SPS-2380BWG
- -40 to 85°C Operating: SPS-2380AWG
- Class 1 Laser International Safety Standard IEC-60825 Compliant

#### APPLICATIONS

- 10GBASE-ZR/ZW
- OC-192 / STM-64 LR2
- 80 km 10G Fibre Channel

#### DESCRIPTION

The SPS-2380WG series single mode transceiver is small form factor pluggable module for bi-directional serial optical data communications such as IEEE 802.3ae 10GBASE-ZR/ZW and 10G Fibre Channel. It is with the SFP 20-pin connector to allow hot plug capability. Digital diagnostic functions are available via an I<sup>2</sup>C. This module is designed for single mode fiber and operates at a nominal wavelength of 1550 nm. The transmitter section uses temperature-stabilized 1550 nm electrical-modulated laser (EML) and is a class 1 laser compliant according to International Safety Standard IEC-60825. The receiver section uses an integrated InGaAs avalanche photo detector preamplifier mounted in an optical header and a limiting post-amplifier IC.

#### LASER SAFETY

This single mode transceiver is a Class 1 laser product. It complies with IEC-60825 and FDA 21 CFR 1040.10 and 1040.11. The transceiver must be operated within the specified temperature and voltage limits. The optical ports of the module shall be terminated with an optical connector or with a dust plug.

#### ORDER INFORMATION

P/No.	Bit Rate (Gb/s)	10GBASE	Distance (km)	Wavelength (nm)	Package	Temp (°C)	RoHS Compliant
SPS-2380WG	10.3	ZR / ZW	80	1550 EML	SFP+ with DMI	0 to 70	Yes
SPS-2380BWG	10.3	ZR / ZW	80	1550 EML	SFP+ with DMI	-5 to 85	Yes
SPS-2380AWG	10.3	ZR / ZW	80	1550 EML	SFP+ with DMI	-40 to 85	Yes

Absolute Maximum Ratings						
Parameter	Symbol	Min	Max	Units	Notes	
Storage Temperature	Tstg	-40	85	°C		
Relative Humidity	RH	5	85	%	Non-condensing	
Operating Case Temperature	Topr	0	70	°C	SPS-2380WG	
		-5	85		SPS-2380BWG	
		-40	85		SPS-2380AWG	
Power Supply Voltage	Vcc	-0.5	3.6	V		
Receiver Input Optical Power	Mip		-4	dBm	Average power	

Recommended Operating Conditions					
Parameter	Symbol	Min	Typ	Max	Units / Notes
Power Supply Voltage	Vcc	3.135	3.3	3.465	V
Operating Case Temperature	Topr	0		70	°C / SPS-2380WG
		-5		85	°C / SPS-2380BWG
		-40		85	°C / SPS-2380AWG
Relative Humidity	RH	5	85	%	Non-condensing
Power Supply Current	I <sub>CC(TX+RX)</sub>		330	500	mA/SPS-2380WG
			350	650	mA/SPS-2380B(A)WG
Data Rate			9.95 / 10.3	10.5	Gb/s

\*\*\*\*\*

Transmitter Optical Specifications (0°C < Topr < 70°C, 3.13V < Vcc < 3.47V)						
Parameter	Symbol	Min	Typ	Max	Units	Notes
Average Launch Power	P <sub>O, AVG</sub>	0		+4	dBm	1
Transmitter Center Wavelength	λ <sub>c</sub>	1530	1550	1565	nm	
Output Spectrum Width	Δλ	---		1	nm	-20 dB width
Side Mode Suppression Ratio	SMSR	30			dB	
Extinction Ratio	ER	8.2			dB	
Relative Intensity Noise	RIN			-130	dB/Hz	
Transmitter and Dispersion Penalty	TDP			3	dB	
Average Launch Power of OFF Transmitter				-30	dBm	

1. Output power is power coupled into a 9/125 μm single-mode fiber.

Receiver Optical Specifications (0°C < Topr < 70°C, 3.13V < Vcc < 3.47V)						
Parameter	Symbol	Min	Typ	Max	Units	Notes
Sensitivity				-23	dBm	2
Receiver Overload	P <sub>MAX</sub>	-7	---		dBm	
LOS -- Deasserted	LOS <sub>D</sub>	---	---	-23	dBm	Transition: low to high
LOS -- Asserted	LOS <sub>A</sub>	-35	---	---	dBm	Transition: high to low
Wavelength of Operation	λ <sub>c</sub>	1530		1565	nm	

2. Measured with average power; BER < 10<sup>-12</sup> and PRBS 2<sup>31</sup>-1 at 10.3125 Gb/s.

Electrical Characteristics						
Parameter	Symbol	Min	Typ	Max	Units	Notes
<b>High-Speed Signal (CML) Interface Specification</b>						
Input Data Rate			9.95 / 10.3	10.5	Gb/s	
Differential Input Impedance	R <sub>in</sub>		100		Ω	
Differential Data Input Amplitude		120		820	mVpp	Internally AC coupled
Output Data Rate			9.95 / 10.3	10.5	Gb/s	
Differential Output Impedance	R <sub>out</sub>		100		Ω	
Differential Data Output Amplitude		350	600	850	mVpp	Internally AC coupled
<b>Low-Speed Signal (LVTTTL) Interface Specification</b>						
Input High Voltage		2.0		V <sub>cc</sub> +0.3	V	
Input Low Voltage		GND		0.8	V	
Output High Voltage		2.4		V <sub>cc</sub>	V	
Output Low Voltage		GND		0.5	V	

\*\*\*\*\*

\*\*\*\*\*  
**CONNECTION DIAGRAM**

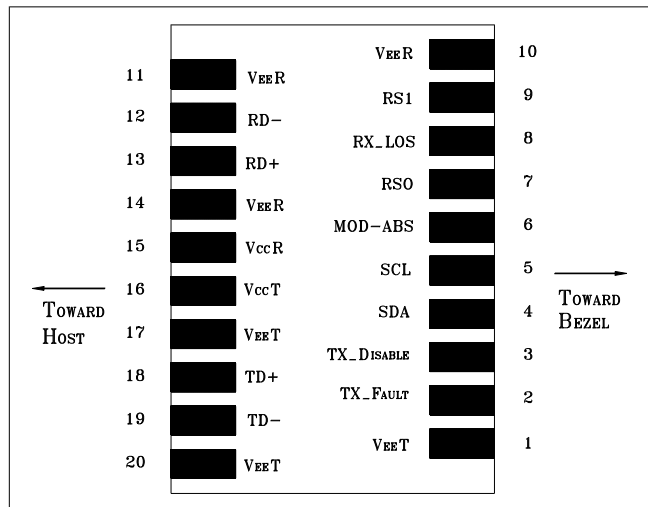

PIN	Signal Name	Description	PIN	Signal Name	Description
1	V <sub>EE</sub> T	Transmitter Signal Ground	11	V <sub>EE</sub> R	Receiver Signal Ground
2	TX_Fault	Transmitter Fault Indication. Logic “1” Output = Laser Fault. Logic “0” Output = Normal Operation	12	RD-	Inverse Receiver Data Out
3	TX_Disable	Logic “1” Input (or no connection) = Laser off, Logic “0” = Laser on.	13	RD+	Receiver Data Out
4	SDA	Modulation Definition 2 – Two wires serial ID Interface	14	V <sub>EE</sub> R	Receiver Signal Ground
5	SCL	Modulation Definition 1 – Two wires serial ID Interface	15	V <sub>CC</sub> R	Receiver Power – 3.3V±5%
6	MOD-ABS	Modulation Definition 0 – Ground in Module	16	V <sub>CC</sub> T	Transmitter Power – 3.3V±5%
7	RS0	RX Rate Select (LVTTL). This pin has an internal 30k pulldown to ground. A signal on this pin will not affect module performance.	17	V <sub>EE</sub> T	Transmitter Signal Ground
8	RX_LOS	Loss of Signal Out (OC).	18	TD+	Transmitter Data In
9	RS1	TX Rate Select (LVTTL). This pin has an internal 30k pulldown to ground. A signal on this pin will not affect module performance.	19	TD-	Inverse Transmitter Data In
10	V <sub>EE</sub> R	Receiver Signal Ground	20	V <sub>EE</sub> T	Transmitter Signal Ground

**MODULE DEFINITION**

Module Definition	PIN 4	PIN 5	PIN 6	Interpretation by Host
4	SDA	SCL	MOD-ABS	Serial module definition protocol

Module Definition 4 specifies a serial definition protocol. For this definition, upon power up, SDA and SCL appear as no connection (NC) and MOD-ABS is TTL LOW. When the host system detects this condition, it activates the serial protocol. The protocol uses the 2-wire serial CMOS E<sup>2</sup>PROM protocol of the ATMEL AT24C01A/02/04 family of components.

## RECOMMENDED CIRCUIT SCHEMATIC

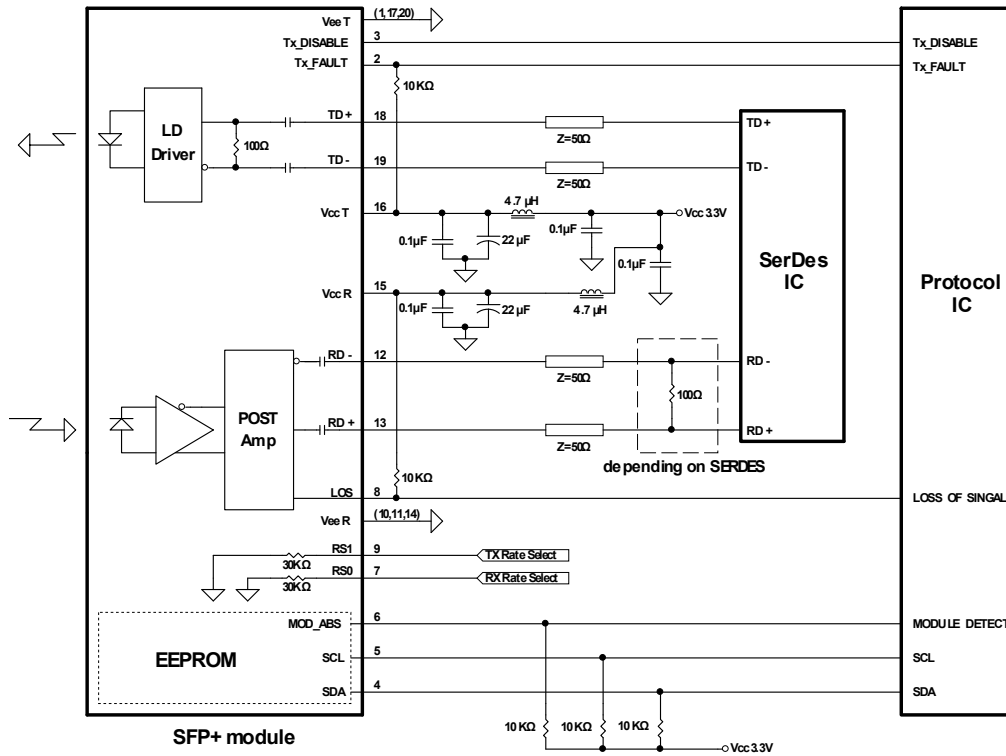

## PACKAGE DIAGRAM

Units in mm

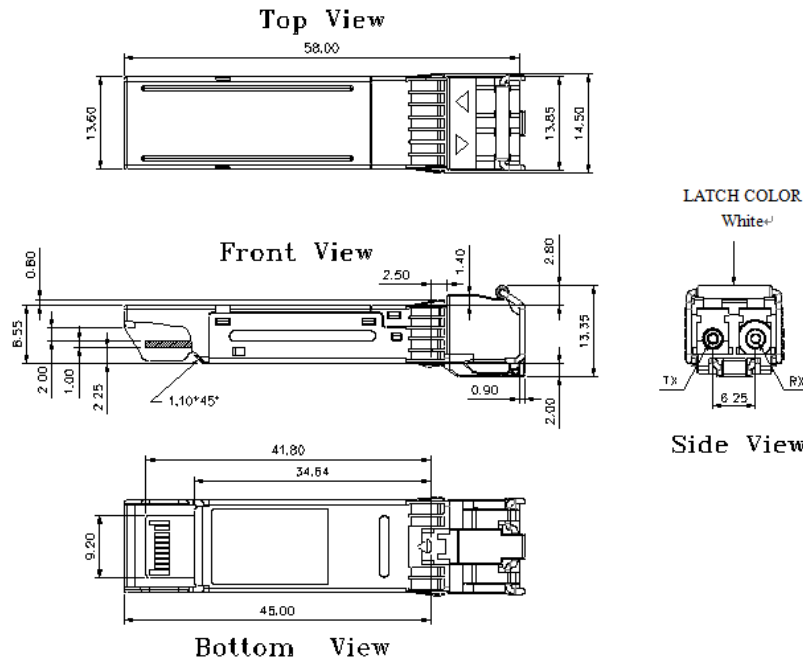

Note: Specifications subject to change without notice.

\*\*\*\*\*  
**REVISION HISTORY**

Version	Subject	Release Date
1.0	Initial datasheet	2010/7/1
2.0	1) Add SPS-2380BWG for extended temperature version 2) Add SPS-2380AWG for industrial temperature version	2010/12/1
3.0	Change LOS Deasserted to -23 dBm	2017/5/2
4.0	Update Package Diagram	2021/1/20