

SPS-2540FWG

(RoHS Compliant)

32G FC / 40 km / 1310 nm Digital Diagnostic SFP28 LC SINGLE-MODE TRANSCEIVER

FEATURES

- Up to 28.05 Gbps Bi-directional Data Links
- Compliant with SFF-8402 SFP28 MSA
- **Compliant with Fibre Channel 3200-SM-LC-L**
- **Compliant with 16G and 8G Fibre Channel**
- **Support OTN 27.95Gbps**
- **Compliant with 25G Ethernet**
- **Support CPRI Option 10 @ 24.33Gbps**
- Built-in dual CDR
- Distance up to 40 km
- 1310nm DFB Transmitter
- SFF-8472 Digital Diagnostic Function
- AC/AC Coupling according to MSA
- Single +3.3 V Power Supply
- RoHS Compliant
- 0 to 70°C Operation
- Class 1 Laser International Safety Standard IEC-60825 Compliant
- **Enhanced EWRAP, and OWRAP operational features**
- **CDR auto sensing**

DESCRIPTION

The SPS-2540FWG series single mode transceiver is a small form factor pluggable module for bi-directional serial optical data communications such as 32x/16x/8x Fibre Channel, OTN OTU4, and 25G Ethernet. It is with the SFP+ 20-pin connector to allow hot plug capability. Digital diagnostic functions are available via an I²C. This module is designed for single mode fiber and operates at a nominal wavelength of 1310 nm. The transmitter section uses a 1310 nm multiple quantum well DFB laser and is a class 1 laser compliant according to International Safety Standard IEC-60825. The receiver section uses an integrated InGaAs detector preamplifier (IDP) mounted in an optical header and a rate selection clock data recovery (CDR) IC.

LASER SAFETY

This single mode transceiver is a Class 1 laser product. It complies with IEC-60825 and FDA 21 CFR 1040.10 and 1040.11. The transceiver must be operated within the specified temperature and voltage limits. The optical ports of the module shall be terminated with an optical connector or with a dust plug.

APPLICATIONS

- Multi-rate 32x / 16x / 8x Fibre Channel
- OTN OTU4
- 25G Ethernet
- CPRI Option 10

ORDER INFORMATION

P/No.	Bit Rate (Gb/s)	FC	Distance (km)	Wavelength (nm)	Package	Case Temp (°C)	RoHS Compliant
SPS-2540FWG	Up to 28.05	32G/16G/8G	40	1310 DFB	SFP28 with DMI	0 to 70	Yes

Absolute Maximum Ratings					
Parameter	Symbol	Min	Max	Units	Notes
Storage Temperature	Tstg	-40	85	°C	
Relative Humidity	RH	5	85	%	Non-condensing
Operating Case Temperature	Topr	0	70	°C	
Power Supply Voltage	Vcc	-0.5	3.6	V	

Recommended Operating Conditions					
Parameter	Symbol	Min	Typ	Max	Units / Notes
Power Supply Voltage	Vcc	3.135	3.3	3.465	V
Operating Case Temperature	Topr	0		70	°C
Relative Humidity	RH	5		85	% / Non-condensing
Power Supply Current	I _{CC(TX+RX)}		270	340	mA
Data Rate		8.5	27.95 / 28.05		Gb/s

Transmitter Optical Specifications (0°C < Topr < 70°C, 3.13V < Vcc < 3.47V)						
Parameter	Symbol	Min	Typ	Max	Units	Notes
Average Launch Power	P _{O, AVG}	5		8	dBm	1
Output Center Wavelength	λ _c	1295	1310	1325	nm	
Output Spectrum Width	Δλ	---		1	nm	-20 dB width
Side Mode Suppression Ratio	SMSR	30			dB	
Extinction Ratio	ER	4.0			dB	
Relative Intensity Noise	RIN			-130	dB/Hz	
Average Launch Power of OFF Transmitter				-30	dBm	

1. Output power is power coupled into a 9/125 μm single-mode fiber.

Receiver Optical Specifications (0°C < Topr < 70°C, 3.13V < Vcc < 3.47V)						
Parameter	Symbol	Min	Typ	Max	Units	Notes
Sensitivity, Average	Sens			-16	dBm	2
Receiver Overload	P _{MAX}	-7	---		dBm	
LOS – Deasserted	LOS _D	---	---	-20	dBm	Transition: low to high
LOS – Asserted	LOS _A	-35	---	---	dBm	Transition: high to low
Wavelength of Operation	λ _c	1260		1355	nm	
Return Loss	ORL	26			dB	

2. Measured @ BER < 10⁻⁶ and PRBS 2³¹-1.

Electrical Characteristics						
Parameter	Symbol	Min	Typ	Max	Units	Notes
High-Speed Signal (CML) Interface Specification						
Input Data Rate		8.5	28.05		Gb/s	
TX Clock Tolerance		-100		+100	ppm	3
Differential Input Impedance	R _{in}		100		Ω	
Differential Data Input Amplitude		150		1000	mV _{pp}	Internally AC coupled
Output Data Rate		8.5	28.05		Gb/s	
RX Clock Tolerance		-100		+100	ppm	3
Differential Output Impedance	R _{out}		100		Ω	
Differential Data Output Amplitude		350	600	700	mV _{pp}	Internally AC coupled
Low-Speed Signal (LVTTTL) Interface Specification						
Input High Voltage		2.0		V _{cc} +0.3	V	
Input Low Voltage		GND		0.8	V	
Output High Voltage		2.4		V _{cc}	V	
Output Low Voltage		GND		0.5	V	

3. Clock tolerance for 25.78Gb/s, 27.95Gb/s, and 28.05Gb/s.

CONNECTION DIAGRAM

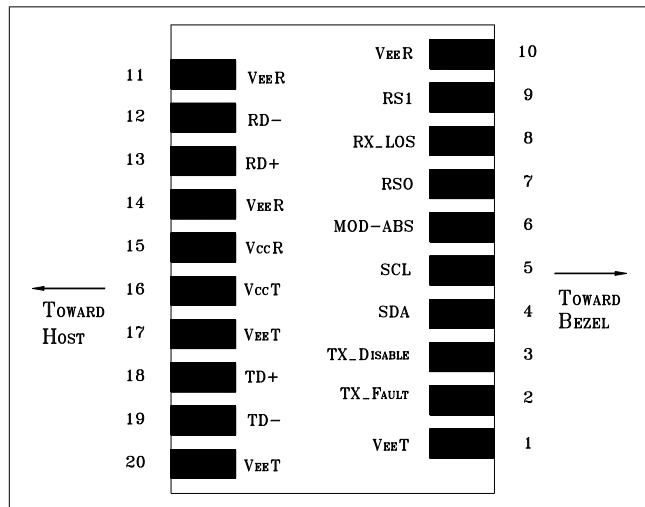

PIN	Signal Name	Description	PIN	Signal Name	Description
1	V _{EE} T	Transmitter Signal Ground	11	V _{EE} R	Receiver Signal Ground
2	TX_Fault	Transmitter Fault Indication. Logic “1” Output = Laser Fault. Logic “0” Output = Normal Operation	12	RD-	Inverse Receiver Data Out
3	TX_Disable	Logic “1” Input (or no connection) = Laser off, Logic “0” = Laser on.	13	RD+	Receiver Data Out
4	SDA	Modulation Definition 2 – Two wires serial ID Interface	14	V _{EE} R	Receiver Signal Ground
5	SCL	Modulation Definition 1 – Two wires serial ID Interface	15	V _{CC} R	Receiver Power – 3.3V±5%
6	MOD-ABS	Modulation Definition 0 – Ground in Module	16	V _{CC} T	Transmitter Power – 3.3V±5%
7	RS0	RX Rate Select: This pin has an internal 30k pulldown to ground. A signal on this pin will not affect module performance.	17	V _{EE} T	Transmitter Signal Ground
8	RX_LOS	Loss of Signal Out (OC).	18	TD+	Transmitter Data In
9	RS1	TX Rate Select: This pin has an internal 30k pulldown to ground. A signal on this pin will not affect module performance.	19	TD-	Inverse Transmitter Data In
10	V _{EE} R	Receiver Signal Ground	20	V _{EE} T	Transmitter Signal Ground

MODULE DEFINITION

Module Definition	PIN 4	PIN 5	PIN 6	Interpretation by Host
4	SDA	SCL	MOD-ABS	Serial module definition protocol

Module Definition 4 specifies a serial definition protocol. For this definition, upon power up, SDA and SCL appear as no connector (NC) and MOD-ABS is TTL LOW. When the host system detects this condition, it activates the serial protocol. The protocol uses the 2-wire serial CMOS E²PROM protocol of the ATMEL AT24C01A/02/04 family of components.

RECOMMENDED CIRCUIT SCHEMATIC

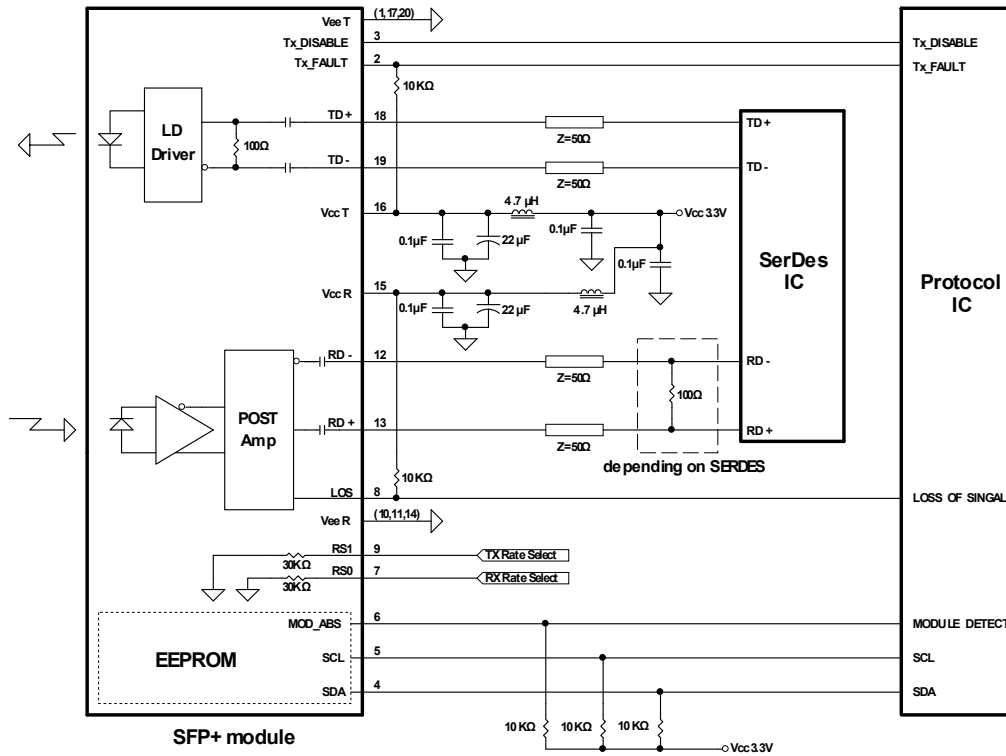

PACKAGE DIAGRAM

Units in mm

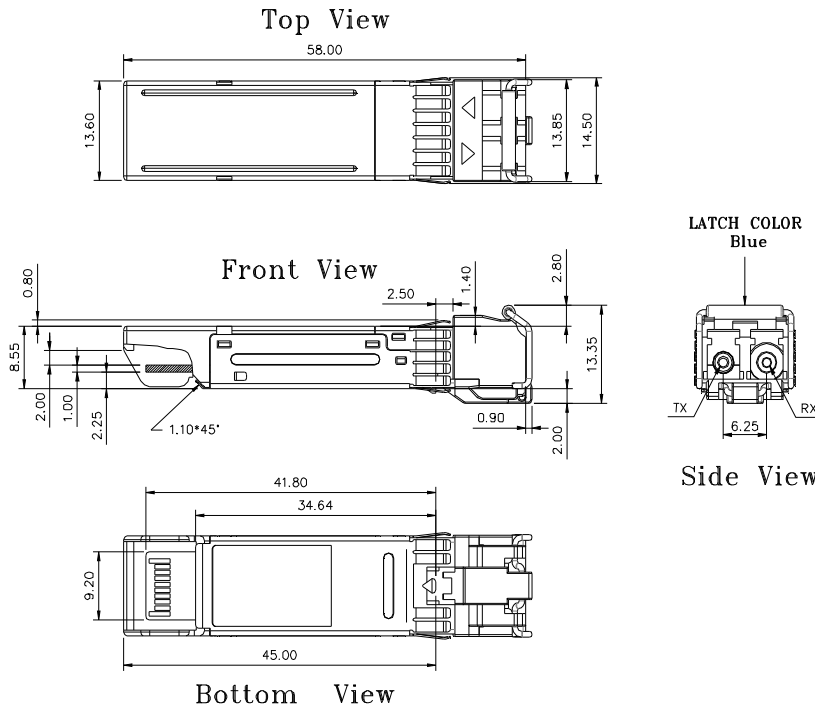

Note: Specifications subject to change without notice.

WRAP AND BYPASS CDR OPERATION FUNCTIONS - SOFT CONTROL (Address A2h, Byte 111).

To assist with local host or remote diagnostic and optimization sequences, electrical and optical wrap functions can be enabled. Optical wrap (OWRAP) takes the received optical signal through CDRs and retransmits it optically out. Electrical wrap (EWRAP) takes the received electrical signal through CDRs and retransmits it electrically out. Optional forward functions can be transmitted outbound the wrapped information via i2c control.

Byte	Bit	Name	Description
111	4-7	Reserved	Reserved.
	3	OWRAP Forward Enable Bit	When set in combination with OWRAP Enable, OWRAP Forward routes incoming SFP+ Rx optical data to both the Tx optical output and the Rx electrical output. Enabling sets bit 2 and clears all other bits in byte 111.
	2	OWRAP Enable Bit	When set, OWRAP routes incoming SFP+ Rx optical data to the Tx optical output. Enabling clears all other bits in byte 111.
	1	EWRAP Forward Enable Bit	When set in combination with EWRAP Enable, EWRAP Forward routes incoming SFP+ Tx electrical data to both Rx electrical output and Tx optical output. Enabling sets bit 0 and clears all other bits in byte 111.
	0	EWRAP Enable Bit	When set, EWRAP Enable routes incoming SFP+ Tx electrical data to the Rx electrical output. Enabling clears all other bits in byte 111.

OWRAP FORWARD ENABLE MODE (I2C CONTROLLED)

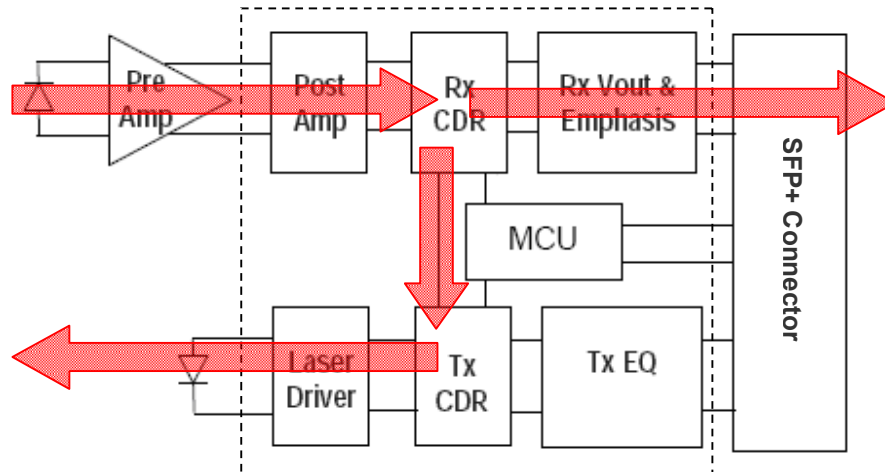

OWRAP ENABLE MODE (I2C CONTROLLED)

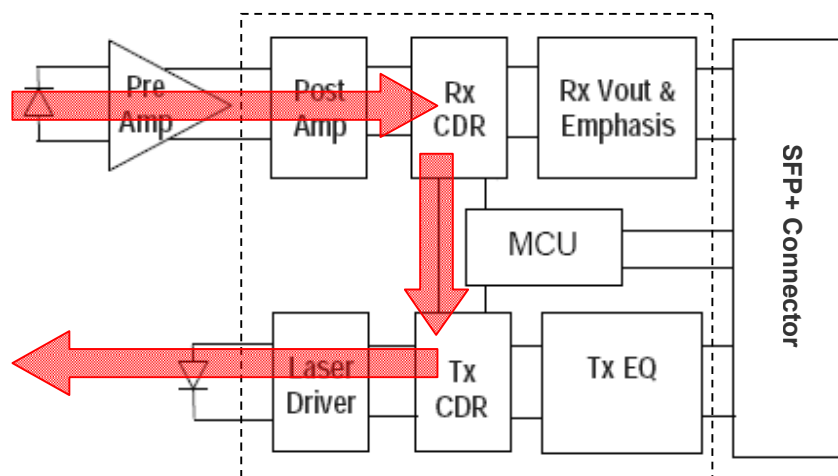

EWRAP FORWARD ENABLE MODE (I2C CONTROLLED)

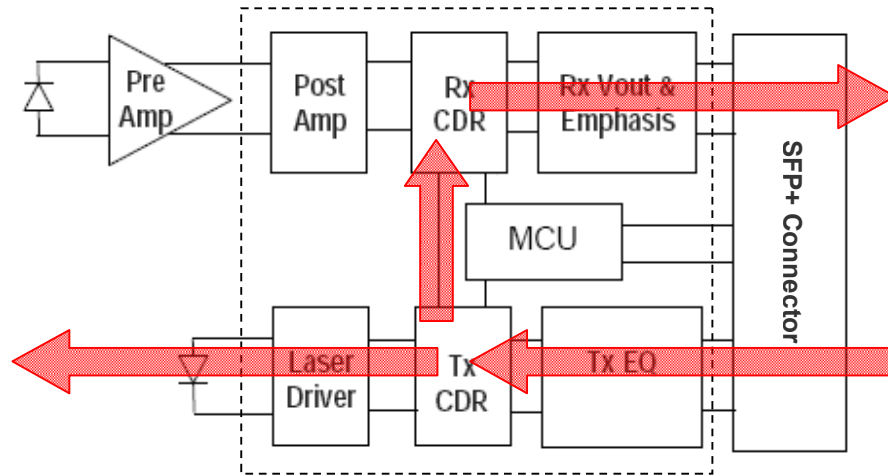

EWRAP ENABLE MODE (I2C CONTROLLED)

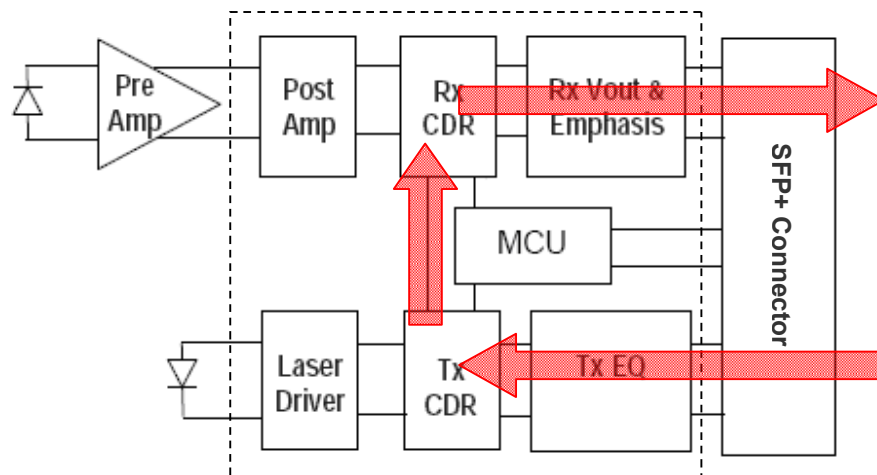

EEPROM Series ID Memory Contents (Address A0h)

Addr.	Hex	ASCII	Note	Addr.	Hex	ASCII	Note	Addr.	Hex	ASCII	Note	Addr.	Hex	ASCII	Note	
0	03		SFP28	32	20			64	18		Power Level 1,	96	00		Vendor specific EEPROM	
1	04			33	20			65	1A		w/ CDR, Uncooled Tx, Txdis, Txfault, LOS	97	00			
2	07		LC	34	20			66	70		28.05Gbps	98	00			
3	00			35	20			67	00			99	00			
4	00			36	00		NA	68			Serial number: each piece with different serial number	100	00			
5	00			37	00		Vendor IEEE OUI	69				101	00			
6	00			38	0E			70				102	00			
7	12		Long Distance (L), Longwave Laser (LL)	39	FA			71				103	00			
8	00			40	53	S	Part Number	72				104	00			
9	01		Single Mode (SM)	41	50	P			73				105	00		
10	68		3200/1600/ 800 Mbytes/sec	42	53	S			74				106	00		
11	06		64B/66B	43	2D	-			75				107	00		
12	FF		> 25Gbps	44	32	2			76				108	00		
13	00			45	35	5			77				109	00		
14	28		40km	46	34	4			78				110	00		
15	FF		> 25.4km	47	30	0			79				111	00		
16	00			48	46	F			80				112	00		
17	00			49	57	W			81				113	00		
18	00			50	47	G		82				114	00			
19	00			51	20			83				115	00			
20	4F	O	Vendor name	52	20			84		Y	Date Code	116	00			
21	50	P		53	20			85		Y		117	00			
22	54	T		54	20			86		M		118	00			
23	4F	O		55	20			87		M		119	00			
24	57	W		56	30	0	Revision, depended on version	88		D		120	00			
25	41	A		57	30	0		89		D		121	00			
26	59	Y		58	30	0		90	20			122	00			
27	20			59	31	1		91	20			123	00			
28	20				60	05		1310 nm	92	68			Monitoring	124	00	
29	20				61	1E			93	F0			Soft Control and Monitoring	125	00	
30	20			62	00		Reserved	94	08		SFF-8472 V12.3	126	00			
31	20			63			Checksum 0-62	95			Checksum 64-94	127	00			

EEPROM Series ID Memory Contents (Address A2h)

Addr.	Hex	Note	Addr.	Hex	Note	Addr.	Hex	Note	Addr.	Hex	Note
0	4B	Temp. High Alarm (75°C)	32	09	Rx Power High Alarm (-6dBm)	64	00	For External Cal.	96		Real Time Temp. MSB
1	00		33	D0		65	00	For External Cal.	97		Real Time Temp. LSB
2	FB	Temp. Low Alarm(-5°C)	34	00	Rx Power Low Alarm (-18dBm)	66	00	For External Cal.	98		Real Time Vcc MSB
3	00		35	9E		67	00	For External Cal.	99		Real Time Vcc LSB
4	49	Temp. High Warming(73°C)	36	07	Rx Power High Warming (-7dBm)	68	3F	For External Cal.	100		Real Time Tx Bias MSB
5	00		37	CB		69	80	For External Cal.	101		Real Time Tx Bias LSB
6	00	Temp. Low Warming (0°C)	38	00	Rx Power Low Warming(-16dBm)	70	00	For External Cal.	102		Real Time Tx Pwr MSB
7	00		39	FB		71	00	For External Cal.	103		Real Time Tx Pwr LSB
8	8C	Voltage High Alarm (3.6V)	40	00	Reserved	72	00	For External Cal.	104		Real Time Rx Pwr MSB
9	A0		41	00	Reserved	73	00	For External Cal.	105		Real Time Rx Pwr LSB
10	75	Voltage Low Alarm(3.0V)	42	00	Reserved	74	00	For External Cal.	106		Reserved
11	30		43	00	Reserved	75	00	For External Cal.	107		Reserved
12	88	Voltage High Warming(3.5V)	44	00	Reserved	76	01	For External Cal.	108		Reserved
13	B8		45	00	Reserved	77	00	For External Cal.	109		Reserved
14	79	Voltage Low Warming (3.1V)	46	00	Reserved	78	00	For External Cal.	110		Tx Dis, Tx Fault, Rx Los
15	18		47	00	Reserved	79	00	For External Cal.	111		OWRAP, EWRAP
16	AF	Tx Bias High Alarm(90mA)	48	00	Reserved	80	01	For External Cal.	112		Alarm Flag
17	C8		49	00	Reserved	81	00	For External Cal.	113		Alarm Flag/Reserved
18	03	Tx Bias Low Alarm(2mA)	50	00	Reserved	82	00	For External Cal.	114		Reserved
19	E8		51	00	Reserved	83	00	For External Cal.	115		Reserved
20	9C	Tx Bias High Warming(80mA)	52	00	Reserved	84	01	For External Cal.	116		Warming Flag
21	40		53	00	Reserved	85	00	For External Cal.	117		Warming Flag/Reserved
22	07	Tx Bias Low Warming(4mA)	54	00	Reserved	86	00	For External Cal.	118		Reserved
23	D0		55	00	Reserved	87	00	For External Cal.	119		Reserved
24	FF	Tx Power High Alarm (8.16dBm)	56	00	For External Cal.	88	01	For External Cal.	120		Vendor Specific
25	F0		57	00	For External Cal.	89	00	For External Cal.	121		
26	62	Tx Power Low Alarm(4dBm)	58	00	For External Cal.	90	00	For External Cal.	122		
27	1F		59	00	For External Cal.	91	00	For External Cal.	123		
28	F6	Tx Power High Warming(8dBm)	60	00	For External Cal.	92	00	For External Cal.	124		
29	78		61	00	For External Cal.	93	00	For External Cal.	125		
30	7B	Tx Power Low Warming (5dBm)	62	00	For External Cal.	94	00	For External Cal.	126		
31	87		63	00	For External Cal.	95		Check Sum	127		

Note: Address 128 – 247: customer R/W eeprom. Address 248 – 255: Vendor Specific.

REVISION HISTORY

Version	Subject	Release Date
1.0	Initial datasheet	2019/6/4