

SPS-4102RWG / SPS-4102BRWG / SPS-4102ARWG

(RoHS Compliant)

6.144 Gbps / 1310 nm / 2 km Digital Diagnostic Multi-Rate CPRI SM SFP+

FEATURES

- CPRI / OBSAI Compatible Optical Interface
- 1G to 6.25G Multi-rate Specification
- Complaint to SFP+ MSA
- Link Distance up to 2 km SMF
- SFF-8472 Digital Diagnostic Function
- AC/AC Coupling according to MSA
- Single +3.3 V Power Supply
- RoHS Compliant
- 0 to 70°C Operating: SPS-4102RWG
- -10 to 85°C Operating: SPS-4102BRWG
- -40 to 85°C Operating: SPS-4102ARWG
- Class 1 Laser International Safety Standard IEC-60825 Compliant

APPLICATIONS

- Radio Base Station
- OBSAI rates 6.144 Gb/s, 3.072 Gb/s, and 1.563 Gb/s
- CPRI rates 6.144Gb/s 4.9152 Gb/s, 2.4576 Gb/s, and 1.2288 Gb/s

DESCRIPTION

The SPS-4102RWG series is a 1 to 6.25 Gb/s single-mode transceiver module for serial optical communications applications for a radio base station system. It is with the SFP+ 20-pin connector to allow hot plug capability. Digital diagnostic functions are available via an I²C. This module is designed for single mode fiber and operates at a nominal wavelength of 1310 nm. The transmitter section uses a 1310 nm multiple quantum well laser and is a class 1 laser compliant according to International Safety Standard IEC-60825. The receiver section uses an integrated InGaAs detector preamplifier (IDP) mounted in an optical header and a limiting post-amplifier IC.

LASER SAFETY

This single mode transceiver is a Class 1 laser product. It complies with IEC-60825 and FDA 21 CFR 1040.10 and 1040.11. The transceiver must be operated within the specified temperature and voltage limits. The optical ports of the module shall be terminated with an optical connector or with a dust plug.

ORDER INFORMATION

P/No.	Bit Rate (Gb/s)	Distance (km)	Wavelength (nm)	Package	Temp. (°C)	RoHS Compliant
SPS-4102RWG	1 to 6.25	2	1310	SFP+ with DMI	0 to 70	Yes
SPS-4102BRWG	1 to 6.25	2	1310	SFP+ with DMI	-10 to 85	Yes
SPS-4102ARWG	1 to 6.25	2	1310	SFP+ with DMI	-40 to 85	Yes

Absolute Maximum Ratings

Parameter	Symbol	Min	Max	Units	Notes
Storage Temperature	Tstg	-40	85	°C	
Operating Case Temperature	Topr	0 -10 -40	70 85 85	°C	SPS-4102RWG SPS-4102BRWG SPS-4102ARWG
Operating Relative Humidity	RH	5	95	%	Non condensing
Power Supply Voltage	Vcc	-0.5	3.6	V	

Recommended Operating Conditions

Parameter	Symbol	Min	Typ	Max	Units / Notes
Power Supply Voltage	Vcc	3.13	3.3	3.47	V
Operating Case Temperature	Topr	0 -10 -40		70 85 85	°C / SPS-4102RWG °C / SPS-4102BRWG °C / SPS-4102ARWG
Power Supply Current	I _{CC(TX+RX)}		250	300	mA
Data Rate		1		6.25	Gb/s

Transmitter Optical Specifications (0°C < Topr < 70°C, 3.13V < Vcc < 3.47V)						
Parameter	Symbol	Min	Typ	Max	Units	Notes
Average Launch Power	$P_{O, Avg}$	-8		0.5	dBm	1
Extinction Ratio	ER	3.5			mW	
Output Center Wavelength	λ_c	1260	1310	1360	nm	
Output Spectrum Width	σ_λ		2		nm	RMS(σ)
Optical Rise / Fall Time	t_r / t_f			70	ps	20 % to 80 %, unfiltered
Relative Intensity Noise	RIN			-128	dB/Hz	
Average Launch Power of OFF Transmitter				-30	dBm	

1. Output power is power coupled into a 9/125 μ m single-mode fiber.

Receiver Optical Specifications (0°C < Topr < 70°C, 3.13V < Vcc < 3.47V)						
Parameter	Symbol	Min	Typ	Max	Units	Notes
Sensitivity	Sens			-14.4	dBm	2, average power
Receiver Overload	P_{MAX}	0.5	---		dBm	
LOS -- Deasserted	LOS_D	---	---	-16	dBm	Transition: low to high
LOS -- Asserted	LOS_A	-30	---	---	dBm	Transition: high to low
Wavelength of Operation	λ_c	1260		1565	nm	
Optical Return Loss	ORL			-12	dB	

2. A valid 8B/10B encoded input is required for receiver sensitivity specification.

Electrical Characteristics						
Parameter	Symbol	Min	Typ	Max	Units	Notes
High-Speed Signal (CML) Interface Specification						
Input Data Rate		1		6.25	Gb/s	
Differential Input Impedance	R_{in}		100		Ω	
Differential Data Input Amplitude		150		1200	mVpp	Internally AC coupled
Output Data Rate		1		6.25	Gb/s	
Differential Output Impedance	R_{out}		100		Ω	
Differential Data Output Amplitude		350	600	700	mVpp	Internally AC coupled
Low-Speed Signal (LVTTTL) Interface Specification						
Input High Voltage		2.0		$V_{cc}+0.3$	V	
Input Low Voltage		GND		0.8	V	
Output High Voltage		2.4		V_{cc}	V	
Output Low Voltage		GND		0.5	V	

CONNECTION DIAGRAM

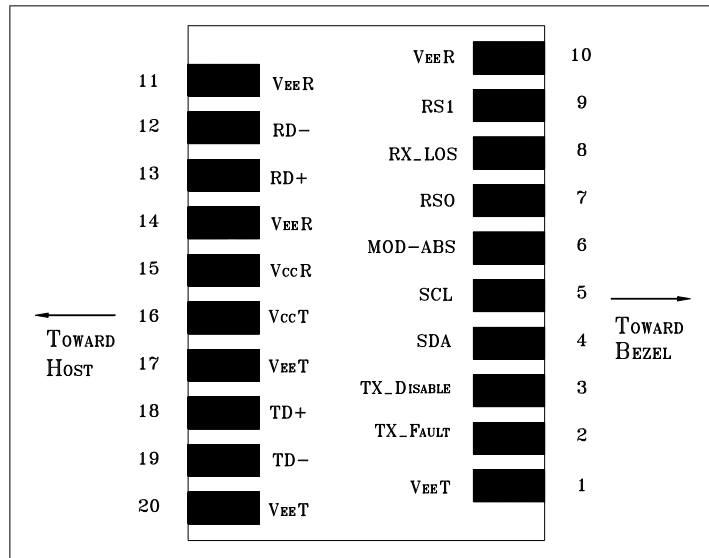

PIN	Signal Name	Description	PIN	Signal Name	Description
1	V _{EE} T	Transmitter Signal Ground	11	V _{EE} R	Receiver Signal Ground
2	TX_Fault	Transmitter Fault Indication. Logic “1” Output = Laser Fault. Logic “0” Output = Normal Operation	12	RD-	Inverse Receiver Data Out
3	TX_Disable	Logic “1” Input (or no connection) = Laser off, Logic “0” = Laser on.	13	RD+	Receiver Data Out
4	SDA	Modulation Definition 2 – Two wires serial ID Interface	14	V _{EE} R	Receiver Signal Ground
5	SCL	Modulation Definition 1 – Two wires serial ID Interface	15	V _{CC} R	Receiver Power – 3.3V±5%
6	MOD-ABS	Modulation Definition 0 – Ground in Module	16	V _{CC} T	Transmitter Power – 3.3V±5%
7	RS0	RX Rate Select (LVTTL). This pin has an internal 30k pulldown to ground. A signal on this pin will not affect module performance.	17	V _{EE} T	Transmitter Signal Ground
8	RX_LOS	Loss of Signal Out (OC).	18	TD+	Transmitter Data In
9	RS1	TX Rate Select (LVTTL). This pin has an internal 30k pulldown to ground. A signal on this pin will not affect module performance.	19	TD-	Inverse Transmitter Data In
10	V _{EE} R	Receiver Signal Ground	20	V _{EE} T	Transmitter Signal Ground

Module Definition

Module Definition	PIN 4	PIN 5	PIN 6	Interpretation by Host
4	SDA	SCL	MOD-ABS	Serial module definition protocol

Module Definition 4 specifies a serial definition protocol. For this definition, upon power up, SDA and SCL appear as no connector (NC) and MOD-ABS is TTL LOW. When the host system detects this condition, it activates the serial protocol. The protocol uses the 2-wire serial CMOS E²PROM protocol of the ATMEL AT24C01A/02/04 family of components.

RECOMMENDED CIRCUIT SCHEMATIC

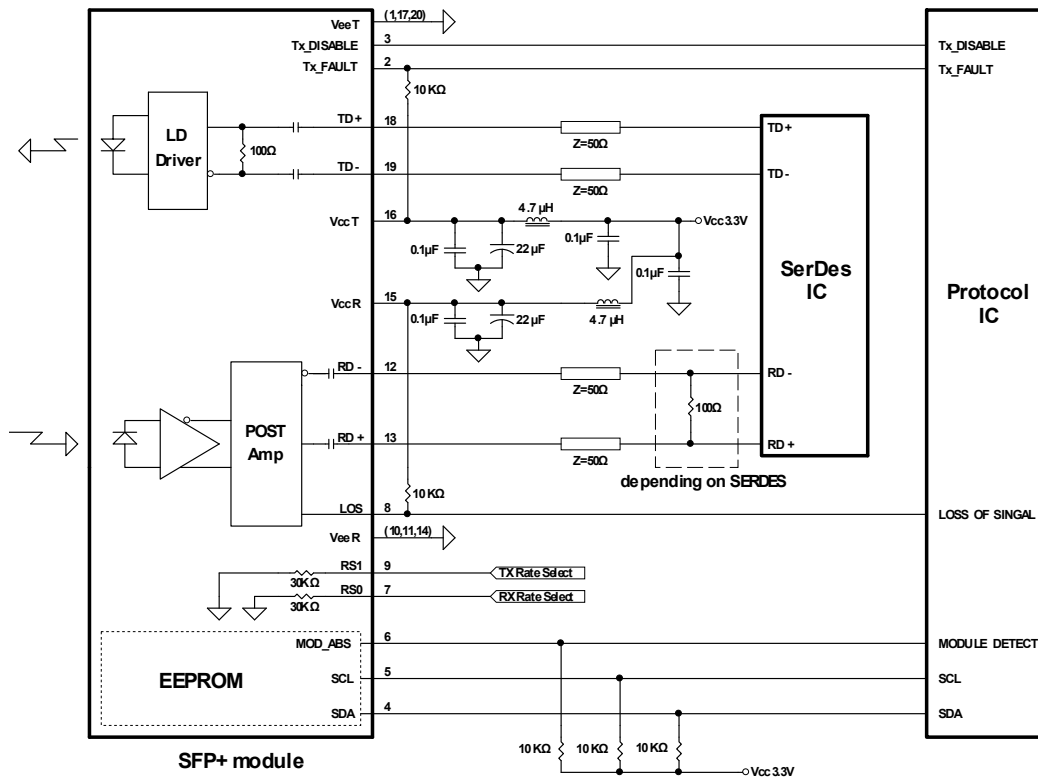

PACKAGE DIAGRAM

Units in mm

Top View

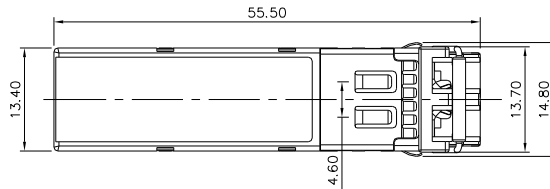

Front View

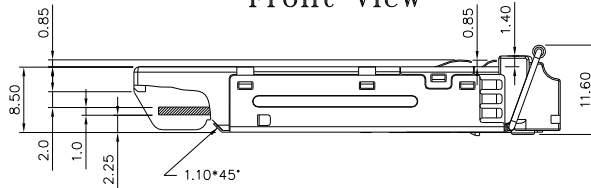

LATCH COLOR
BLUE : SM

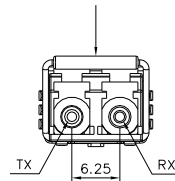

Side View

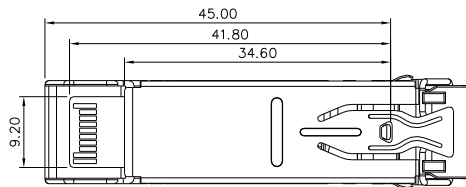

Bottom View

REVISION HISTORY

Version	Subject	Release Date
1.0	Initial datasheet	2009/7/1
2.0	Extend data rate from 1 Gb/s to 6.25Gb/s	2010/9/1
2.1	Add 6.144Gb/s to CPRI rates	2017/9/15