

SPS-53200WG / SPS-53200BWG / SPS-53200AWG

(RoHS Compliant)

3.3V / 1550 nm / 622 Mbps **Digital Diagnostic** LC SFP SINGLE-MODE TRANSCEIVER

FEATURES

- Hot-Pluggable SFP Footprint LC Optical Transceiver
- Small Form-Factor Pluggable (SFP) MSA Compatible
- Compliant with Long-Reach SONET OC-12 / SDH STM-4
- SFF-8472 Digital Diagnostic Function
- 1550 nm DFB LD Transmitter
- APD High Sensitivity Receiver
- **41 dB Power Budget at Least**
- **Distance up to 200 km**
- AC/AC Coupling according to MSA
- Single +3.3 V Power Supply
- RoHS Compliant
- 0 to 70°C Operation: SPS-53200G
- -10 to 85°C Operation: SPS-53200BG
- -40 to 85°C Operation: SPS-53200AG
- Class 1 Laser International Safety Standard IEC-60825 Compliant

APPLICATIONS

- ATM Switches and Routers
- SONET / SDH Switch Infrastructure
- XDSL Applications
- Metro Edge Switching

DESCRIPTION

The SPS-53200WG series single mode transceiver is small form factor pluggable module for bi-directional serial optical data communications such as SONET OC-12 / SDH STM-4 and Fiber Channel. It is with the SFP 20-pin connector to allow hot plug capability. Digital diagnostic functions are available via an I²C. This module is designed for single mode fiber and operates at a nominal wavelength of 1550 nm. A guaranteed minimum optical link budget of 41 dB is offered which can correspond to a link distance of over 200 km (assuming worst case fiber loss of 0.19 dB/km). The transmitter section uses a multiple quantum well 1550 nm DFB laser and is a class 1 laser compliant according to International Safety Standard IEC-60825. The receiver section uses an integrated InGaAs Avalanche photodetector preamplifier mounted in an optical header and a limiting post-amplifier IC.

LASER SAFETY

This single mode transceiver is a Class 1 laser product. It complies with IEC-60825 and FDA 21 CFR 1040.10 and 1040.11. The transceiver must be operated within the specified temperature and voltage limits. The optical ports of the module shall be terminated with an optical connector or with a dust plug.

ORDER INFORMATION

P/No.	Bit Rate (Mb/s)	SONET /SDH	Distance (km)	Wavelength (nm)	Package	Temp. (°C)	TX Power (dBm)	RX Sens. (dBm)	RoHS Compliant
SPS-53200WG	622		200	1550 DFB	LC SFP with DMI	0 to 70	6 to 3	-38	Yes
SPS-53200BWG	622		200	1550 DFB	LC SFP with DMI	-10 to 85	6 to 3	-38	Yes
SPS-53200AWG	622		200	1550 DFB	LC SFP with DMI	-40 to 85	6 to 3	-38	Yes

Absolute Maximum Ratings

Parameter	Symbol	Min	Max	Units	Notes
Storage Temperature	Tstg	-40	85	°C	
Operating Case Temperature	Topr	0	70	°C	SPS-53200WG
		-10	85		SPS-53200BWG
		-40	85		SPS-53200AWG
Power Supply Voltage	Vcc	-0.5	3.6	V	

Recommended Operating Conditions

Parameter	Symbol	Min	Typ	Max	Units / Notes
Power Supply Voltage	Vcc	3.13	3.3	3.47	V
Operating Case Temperature	Topr	0		70	°C / SPS-53200WG
		-10		85	°C / SPS-53200BWG
		-40		85	°C / SPS-53200AWG
Power Supply Current	I _{CC(TX+RX)}		230	300	mA
Data Rate		155	622		Mb/s

Transmitter Specifications (0°C < Topr < 70°C, 3.13V < Vcc < 3.47V)

Parameter	Symbol	Min	Typ	Max	Units	Notes
Optical						
Optical Transmit Power	Po	3	---	6	dBm	1
Output Center Wavelength	λ	1530	1550	1570	nm	
Output Spectrum Width	$\Delta\lambda$	---	---	1	nm	-20 dB Width
Side Mode Suppression Ratio	SMSR	30			dB	
Extinction Ratio	E_R	10	---	---	dB	
Output Eye	Compliant with Bellcore TR-NWT-000253 and ITU recommendation G.957					
Optical Rise Time	t_r			1.2	ns	10 % to 90% Values
Optical Fall Time	t_f			1.2	ns	10 % to 90% Values
Relative Intensity Noise	RIN			-120	dB/Hz	
Electrical						
Data Input Current – Low	I_{IL}	-350			μ A	
Data Input Current – High	I_{IH}			350	μ A	
Differential Input Voltage	$V_{IH} - V_{IL}$	0.5		2.4	V	Peak-to-Peak
TX Disable Input Voltage – Low	T_{DIS_L}	0		0.5	V	2
TX Disable Input Voltage – High	T_{DIS_H}	2.0		Vcc	V	2
TX Disable Assert Time	T_{ASSERT}			1	ms	
TX Disable Deassert Time	$T_{DEASSERT}$			50	μ s	
TX Fault Output Voltage -- Low	T_{FaultL}	0		0.5	V	3
TX Fault Output Voltage -- High	T_{FaultH}	2.0		Vcc+0.3	V	3

1. Output power is power coupled into a 9/125 μ m single mode fiber.
2. There is an internal 4.7K to 10K ohm pull-up resistor to VccTX.
3. Open collector compatible, 4.7K to 10K ohm pull-up to Vcc (Host Supply Voltage).

Receiver Specifications (0°C < Topr < 70°C, 3.13V < Vcc < 3.47V)

Parameter	Symbol	Min	Typ	Max	Units	Notes
Optical						
Sensitivity	Sens			-38	dBm	4
Maximum Input Power	Pin	-9			dBm	4
Signal Detect -- Asserted	Pa	---		-38	dBm	Transition: low to high
Signal Detect -- Deasserted	Pd	-47	---	---	dBm	Transition: high to low
Signal detect -- Hysteresis		1.0	---		dB	
Wavelength of Operation		1100	---	1600	nm	
Electrical						
Differential Output Voltage	$V_{OH} - V_{OL}$	0.6		2.0	V	
Output LOS Voltage -- Low	V_{OL}	0		0.5	V	5
Output LOS Voltage -- High	V_{OH}	2.0		Vcc+0.3	V	5

4. Measured at 2²³-1 PRBS at BER 1E-10.
5. Open collector compatible, 4.7K to 10K ohm pull-up to Vcc (Host Supply Voltage).

CONNECTION DIAGRAM

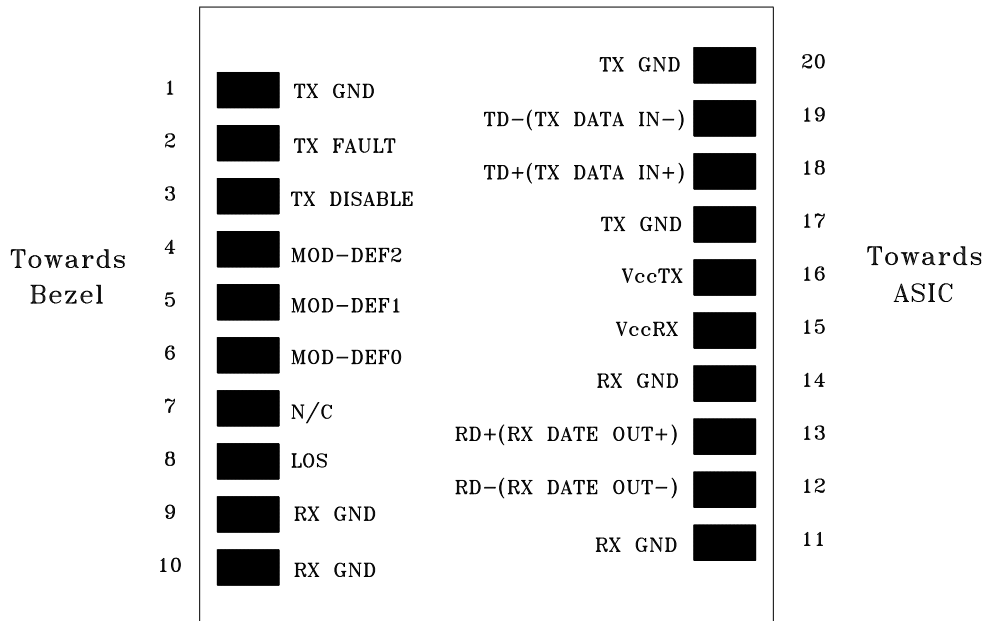

PIN	Signal Name	Description	PIN	Signal Name	Description
1	TX GND	Transmitter Ground	11	RX GND	Receiver Ground
2	TX Fault	Transmitter Fault Indication	12	RX DATA OUT-	Inverse Receiver Data Out
3	TX Disable	Transmitter Disable (Module disables on high or open)	13	RX DATA OUT+	Receiver Data Out
4	MOD-DFE2	Modulation Definition 2 – Two wires serial ID Interface	14	RX GND	Receiver Ground
5	MOD-DEF1	Modulation Definition 1 – Two wires serial ID Interface	15	Vcc RX	Receiver Power – 3.3V±5%
6	MOD-DEF0	Modulation Definition 0 – Ground in Module	16	Vcc TX	Transmitter Power – 3.3V±5%
7	N/C	Not Connected	17	TX GND	Transmitter Ground
8	LOS	Loss of Signal	18	TX DATA IN+	Transmitter Data In
9	RX GND	Receiver Ground	19	TX DATA IN-	Inverse Transmitter Data In
10	RX GND	Receiver Ground	20	TX GND	Transmitter Ground

Module Definition

Module Definition	MOD-DEF2 PIN 4	MOD-DEF1 PIN 5	MOD-DEF0 PIN 6	Interpretation by Host
4	SDA	SCL	LV-TTL Low	Serial module definition protocol

Module Definition 4 specifies a serial definition protocol. For this definition, upon power up, MOD-DEF(1:2) appear as no connector (NC) and MOD-DEF(0) is TTL LOW. When the host system detects this condition, it activates the serial protocol. The protocol uses the 2-wire serial CMOS E²PROM protocol of the ATMEL AT24C01A/02/04 family of components.

RECOMMENDED CIRCUIT SCHEMATIC

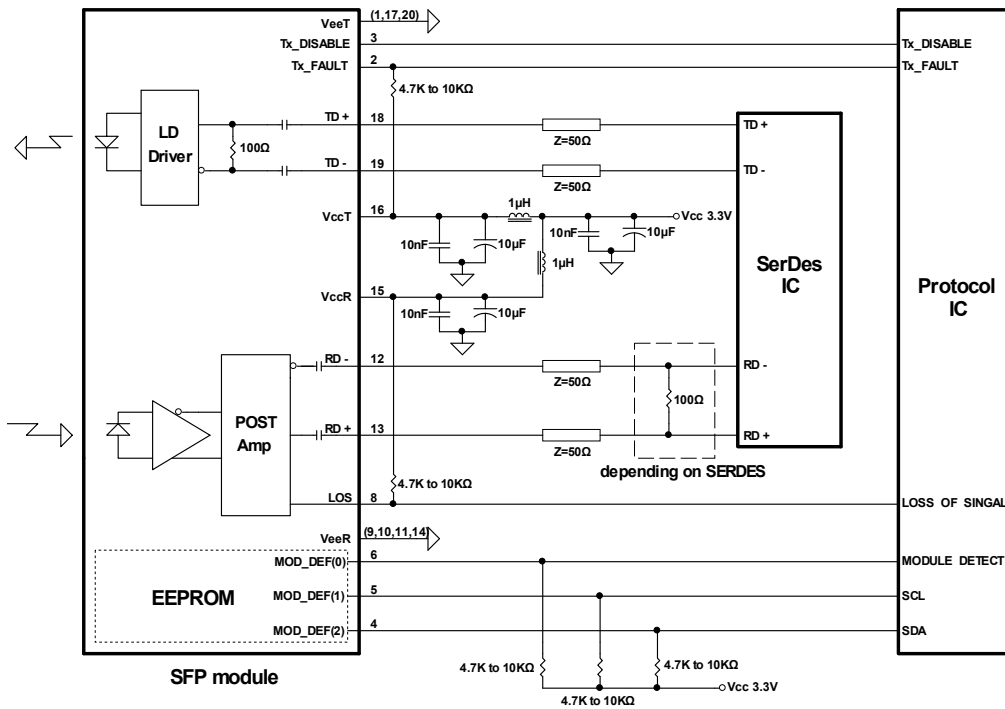

PACKAGE DIAGRAM

Units in mm

Top View

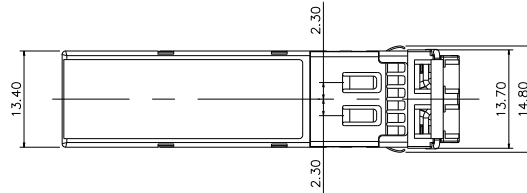

Front View

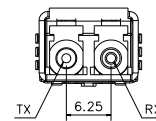
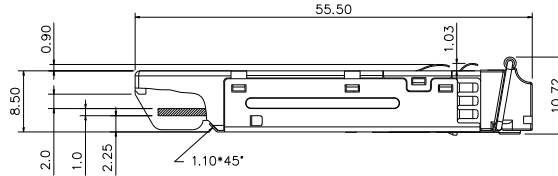

Side View

Bottom View

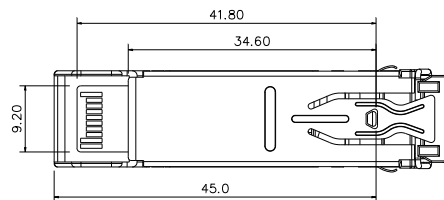

Note: Specifications subject to change without notice.

Revision History

Version	Subject	Release Date
1.0	Initial datasheet	2008/6/1
2.0	Add -10 to 85 °C SPS-53200BWG	2008/8/1
3.0	Add -40 to 85 °C SPS-53200AWG	2009/1/1
4.0	Add min. Data Rate 155 Mb/s	2019/6/18