

SPS-6311W-CXX0G

(RoHS Compliant)

16G FC / CWDM / 10 km Digital Diagnostic SFP+ LC SINGLE-MODE TRANSCEIVER

FEATURES

- Up to 14.025 Gbps Bi-directional Data Links
- Compliant with SFP+ MSA
- Compliance with Fibre Channel 1600-SM-LC-L
- Compliant with 8G and 4G Fibre Channel
- **Temperature-stabilized CWDM EML Transmitter**
-- 8 λ from 1470 nm to 1610 nm
- **Maximum Link Length of 10 km at 14.25 Gb/s**
- **Power Budget > 11 dB**
- SFF-8472 Digital Diagnostic Function
- AC/AC Coupling according to MSA
- Single +3.3 V Power Supply
- RoHS Compliant
- 0 to 70°C Operating
- Class 1 Laser International Safety Standard IEC-60825 Compliant

APPLICATIONS

- Multi-rate 16x / 8x / 4x Fibre Channel
- 10G FCoE

DESCRIPTION

The SPS-6311W-CXX0G series single mode transceiver is small form factor pluggable module for bi-directional serial optical data communications such as 16x/8x/4x Fibre Channel. It is with the SFP+ 20-pin connector to allow hot plug capability. Digital diagnostic functions are available via an I²C. This module is designed for single mode fiber and operates at a nominal wavelength of CWDM wavelength. There are eight center wavelengths available from 1470 nm to 1610 nm, with each step 20 nm. A guaranteed minimum optical link budget of 11 dB is offered. The transmitter section uses temperature-stabilized DWDM electrical-modulated laser (EML) and is a class 1 laser compliant according to International Safety Standard IEC-60825. The receiver section uses an integrated InGaAs detector preamplifier (IDP) mounted in an optical header and a post amplifier IC.

LASER SAFETY

This single mode transceiver is a Class 1 laser product. It complies with IEC-60825 and FDA 21 CFR 1040.10 and 1040.11. The transceiver must be operated within the specified temperature and voltage limits. The optical ports of the module shall be terminated with an optical connector or with a dust plug.

ORDER INFORMATION

P/No.	Bit Rate (Gb/s)	FC	Power Budget (dB)	Wavelength (nm)	Package	Temp. (°C)	RoHS Compliant
SPS-6311W-CXX0G	14.025	16G / 8G / 4G	>11	CWDM	SFP+ with DMI	0 to 70	Yes

CWDM* Wavelength (0 to 70°C)

Central Wavelength	Min. (nm)	Typ. (nm)	Max. (nm)	Label	Central Wavelength	Min. (nm)	Typ. (nm)	Max. (nm)	Label
-C470	1464.5	1470	1477.5	C47	-C550	1544.5	1550	1557.5	C55
-C490	1484.5	1490	1497.5	C49	-C570	1564.5	1570	1577.5	C57
-C510	1504.5	1510	1517.5	C51	-C590	1584.5	1590	1597.5	C59
-C530	1524.5	1530	1537.5	C53	-C610	1604.5	1610	1617.5	C61

CWDM*: 8 Wavelengths from 1470 nm to 1610 nm, each step 20 nm.

Absolute Maximum Ratings					
Parameter	Symbol	Min	Max	Units	Notes
Storage Temperature	Tstg	-40	85	°C	
Operating Case Temperature	Topr	0	70	°C	
Power Supply Voltage	Vcc	-0.5	3.6	V	

Recommended Operating Conditions					
Parameter	Symbol	Min	Typ	Max	Units / Notes
Power Supply Voltage	Vcc	3.13	3.3	3.47	V
Operating Case Temperature	Topr	0		70	°C
Power Supply Current	I _{CC(TX+RX)}		340	520	mA
Data Rate		4.25	14.025		Gb/s

Transmitter Optical Specifications (0°C < Topr < 70°C, 3.13V < Vcc < 3.47V)						
Parameter	Symbol	Min	Typ	Max	Units	Notes
Average Launch Power	$P_{O, Avg}$	-3		2	dBm	1
Extinction Ratio	ER	6				
Output Center Wavelength	λ	$\lambda_c - 5.5$	λ_c	$\lambda_c + 7.5$	nm	2
Output Spectrum Width	σ_λ			1	nm	-20 dB width
Side Mode Suppression Ratio	SMSR	30			dB	
Transmitter and Dispersion Penalty	TDP			2	dB	
Relative Intensity Noise	RIN			-130	dB/Hz	
Average Launch Power of OFF Transmitter				-30	dBm	

- Output power is power coupled into a 9/125 μ m single-mode fiber.
- ITU-T G.694.2 CWDM wavelength from 1470 nm to 1610 nm, each step 20 nm.

Receiver Optical Specifications (0°C < Topr < 70°C, 3.13V < Vcc < 3.47V)						
Parameter	Symbol	Min	Typ	Max	Units	Notes
Unstressed Sensitivity at 14.025 Gb/s	Sens			-14	dBm	2 / Average
Receiver Overload	P_{MAX}	1	---		dBm	
LOS -- Deasserted	LOS_D	---	---	-14	dBm	Transition: low to high
LOS -- Asserted	LOS_A	-24	---	---	dBm	Transition: high to low
Wavelength of Operation	λ_c	1260		1565	nm	
Optical Return Loss	ORL			-12	dB	

- Measured with worst ER; BER < 10⁻¹² and PRBS 2³¹-1.

Electrical Characteristics						
Parameter	Symbol	Min	Typ	Max	Units	Notes
High-Speed Signal (CML) Interface Specification						
Input Data Rate		4.25	14.025		Gb/s	
TX Clock Tolerance				± 100	ppm	4
Differential Input Impedance	Rin		100		Ω	
Differential Data Input Amplitude		150		1200	mVpp	Internally AC coupled
Output Data Rate		4.25	14.025		Gb/s	
RX Clock Tolerance				± 100	ppm	4
Differential Output Impedance	Rout		100		Ω	
Differential Data Output Amplitude		350	600	700	mVpp	Internally AC coupled
Low-Speed Signal (LVTTTL) Interface Specification						
Input High Voltage		2.0		Vcc+0.3	V	
Input Low Voltage		GND		0.8	V	
Output High Voltage		2.4		Vcc	V	
Output Low Voltage		GND		0.5	V	

- Clock tolerance for 14.025 Gb/s, 8.5Gb/s and 4.25 Gb/s.

CONNECTION DIAGRAM

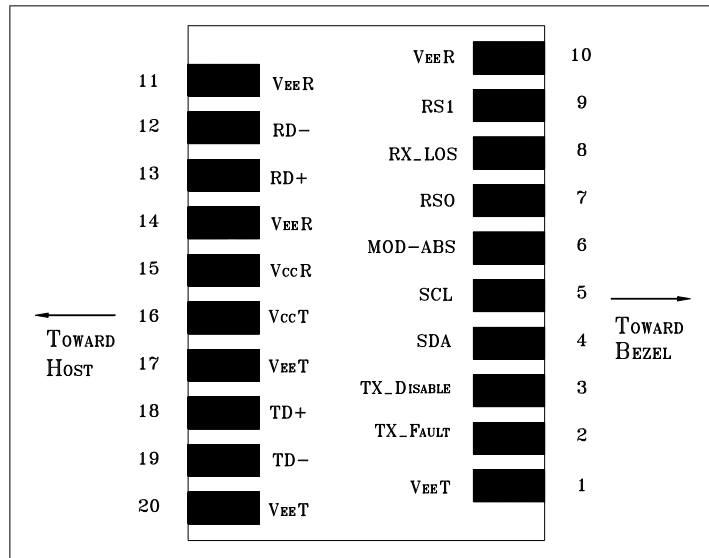

PIN	Signal Name	Description	PIN	Signal Name	Description
1	V _{EE} T	Transmitter Signal Ground	11	V _{EE} R	Receiver Signal Ground
2	TX_Fault	Transmitter Fault Indication. Logic “1” Output = Laser Fault. Logic “0” Output = Normal Operation	12	RD-	Inverse Receiver Data Out
3	TX_Disable	Logic “1” Input (or no connection) = Laser off, Logic “0” = Laser on.	13	RD+	Receiver Data Out
4	SDA	Modulation Definition 2 – Two wires serial ID Interface	14	V _{EE} R	Receiver Signal Ground
5	SCL	Modulation Definition 1 – Two wires serial ID Interface	15	V _{CC} R	Receiver Power – 3.3V±5%
6	MOD-ABS	Modulation Definition 0 – Ground in Module	16	V _{CC} T	Transmitter Power – 3.3V±5%
7	RS0	RX Rate Select (LVTTL). This pin has an internal 30k pulldown to ground. A signal on this pin will not affect module performance.	17	V _{EE} T	Transmitter Signal Ground
8	RX_LOS	Loss of Signal Out (OC).	18	TD+	Transmitter Data In
9	RS1	TX Rate Select (LVTTL). This pin has an internal 30k pulldown to ground. A signal on this pin will not affect module performance.	19	TD-	Inverse Transmitter Data In
10	V _{EE} R	Receiver Signal Ground	20	V _{EE} T	Transmitter Signal Ground

MODULE DEFINITION

Module Definition	PIN 4	PIN 5	PIN 6	Interpretation by Host
4	SDA	SCL	MOD-ABS	Serial module definition protocol

Module Definition 4 specifies a serial definition protocol. For this definition, upon power up, SDA and SCL appear as no connection (NC) and MOD-ABS is TTL LOW. When the host system detects this condition, it activates the serial protocol. The protocol uses the 2-wire serial CMOS E²PROM protocol of the ATMEL AT24C01A/02/04 family of components.

RECOMMENDED CIRCUIT SCHEMATIC

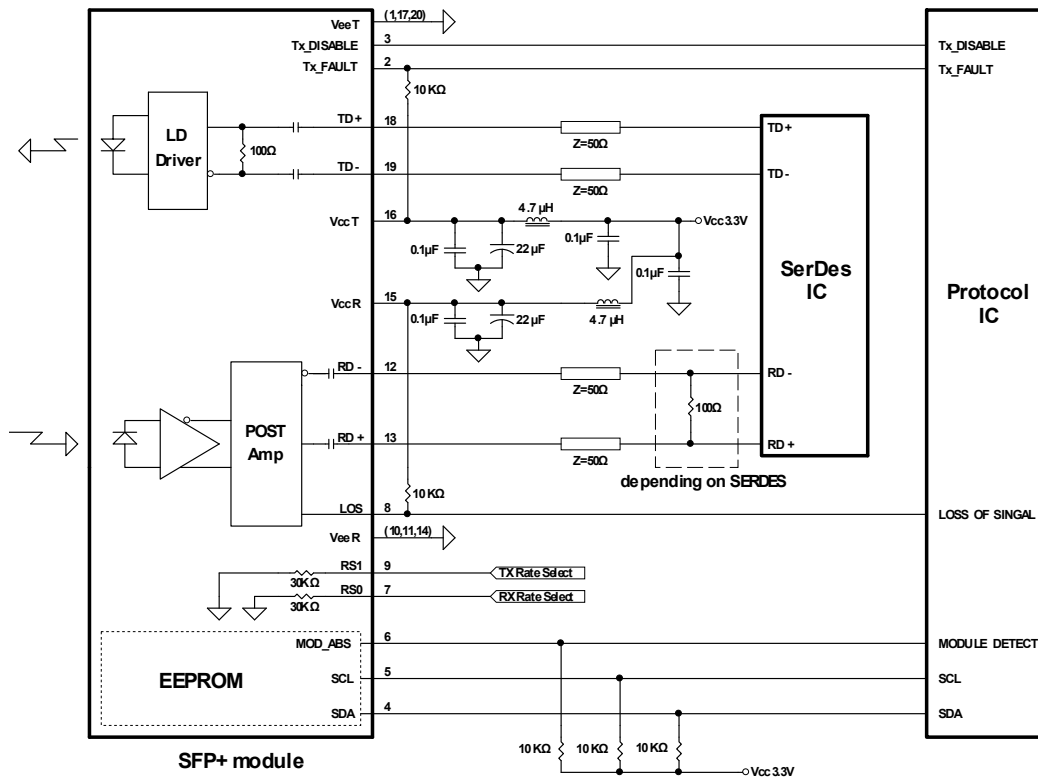

PACKAGE DIAGRAM

Units in mm

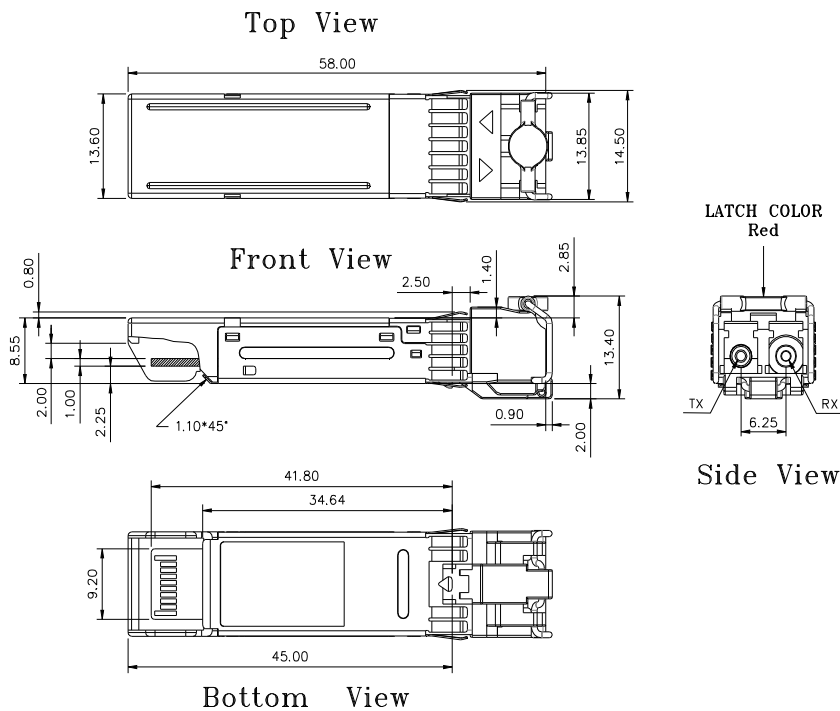

Note: Specifications subject to change without notice.

EEPROM Series ID Memory Contents (Address A0h)

Addr.	Hex	ASCII	Note	Addr.	Hex	ASCII	Note	Addr.	Hex	ASCII	Note	Addr.	Hex	ASCII	Note
0	03		SFP+	32	20			64	06		Cooled Tx,	96	00		Vendor specific EEPROM
1	04			33	20			65	1A		Power Level 2, Txdis, Txfault, LOS enable	97	00		
2	07		LC	34	20			66	00		Up bit rate	98	00		
3	20		10G Base-LR	35	20			67	00		Low bit rate	99	00		
4	00			36	00		NA	68			Serial number: each piece with different serial number	100	00		
5	00			37	00		Vendor IEEE OUI	69				101	00		
6	00			38	0E			70				102	00		
7	10		Long Distance (L)	39	FA			71				103	00		
8	10		Longwave Laser (LL)	40	53	S	Part Number	72				104	00		
9	01		Single Mode (SM)	41	50	P		73			105	00			
10	F0		1600/1200/800/400 Mbytes/sec	42	53	S		74			106	00			
11	06		64B/66B	43	2D	-		75			107	00			
12	8C		14.025Gbps	44	36	6		76			108	00			
13	00			45	33	3		77			109	00			
14	0A		10km	46	31	1		78			110	00			
15	64		10km	47	31	1		79			111	00			
16	00			48	57	W		80			112	00			
17	00			49	2D	-		81			113	00			
18	00			50	43	C		82			114	00			
19	00			51	3X	X		83			115	00			
20	4F	O	Vendor name	52	3X	X		84			Date Code	116	00		
21	50	P		53	30	0		85				117	00		
22	54	T		54	47	G		86				118	00		
23	4F	O		55	20			87				119	00		
24	57	W		56	30	0	Revision, depended on version	88				120	00		
25	41	A		57	30	0		89				121	00		
26	59	Y		58	30	0		90				122	00		
27	20			59	30	1		91				123	00		
28	20			60			1XX0 nm	92	68			Monitoring	124	00	
29	20			61				93	F0			Soft Control	125	00	
30	20		62	00		Reserved	94	05		SFF-8472V11.0	126	00			
31	20		63			Checksum 0-62	95			Checksum 64-94	127	00			

EEPROM Series ID Memory Contents (Address A2h)

Addr.	Hex	Note	Addr.	Hex	Note	Addr.	Hex	Note	Addr.	Hex	Note
0	4B	Temp. High Alarm (75°C)	32	3D	Rx Power High Alarm (2dBm)	64	00	For External Cal.	96		Real Time Temp. MSB
1	00		33	E9		65	00	For External Cal.	97		Real Time Temp. LSB
2	FB	Temp. Low Alarm(-5°C)	34	00	Rx Power Low Alarm (-16dBm)	66	00	For External Cal.	98		Real Time Vcc MSB
3	00		35	FB		67	00	For External Cal.	99		Real Time Vcc LSB
4	46	Temp. High Warming(70°C)	36	31	Rx Power High Warming (1dBm)	68	3F	For External Cal.	100		Real Time Tx Bias MSB
5	00		37	2D		69	80	For External Cal.	101		Real Time Tx Bias LSB
6	00	Temp. Low Warming (0°C)	38	01	Rx Power Low Warming(-14dBm)	70	00	For External Cal.	102		Real Time Tx Pwr MSB
7	00		39	8E		71	00	For External Cal.	103		Real Time Tx Pwr LSB
8	8C	Voltage High Alarm (3.6V)	40	00	Reserved	72	00	For External Cal.	104		Real Time Rx Pwr MSB
9	A0		41	00	Reserved	73	00	For External Cal.	105		Real Time Rx Pwr LSB
10	75	Voltage Low Alarm(3.0V)	42	00	Reserved	74	00	For External Cal.	106		Reserved
11	30		43	00	Reserved	75	00	For External Cal.	107		Reserved
12	88	Voltage High Warming(3.5V)	44	00	Reserved	76	01	For External Cal.	108		Reserved
13	B8		45	00	Reserved	77	00	For External Cal.	109		Reserved
14	79	voltage Low Warming (3.1V)	46	00	Reserved	78	00	For External Cal.	110		Tx Dis, Tx Fault, Rx Los
15	18		47	00	Reserved	79	00	For External Cal.	111		Reserved
16	EA	Tx Bias High Alarm(120mA)	48	00	Reserved	80	01	For External Cal.	112		Alarm Flag
17	60		49	00	Reserved	81	00	For External Cal.	113		Alarm Flag/Reserved
18	27	Tx BiasLow Alarm(20mA)	50	00	Reserved	82	00	For External Cal.	114		Reserved
19	10		51	00	Reserved	83	00	For External Cal.	115		Reserved
20	D6	Tx Bias High Warming(110mA)	52	00	Reserved	84	01	For External Cal.	116		Warming Flag
21	D8		53	00	Reserved	85	00	For External Cal.	117		Warming Flag/Reserved
22	3A	Tx Bias Low Warming(30mA)	54	00	Reserved	86	00	For External Cal.	118		Reserved
23	98		55	00	Reserved	87	00	For External Cal.	119		Reserved
24	4D	Tx Power High Alarm (3dBm))	56	00	For External Cal.	88	01	For External Cal.	120		Vendor Specific
25	F1		57	00	For External Cal.	89	00	For External Cal.	121		
26	0F	Tx Power Low Alarm(-4dBm)	58	00	For External Cal.	90	00	For External Cal.	122		
27	8D		59	00	For External Cal.	91	00	For External Cal.	123		
28	3D	Tx Power High Warming(2dBm)	60	00	For External Cal.	92	00	For External Cal.	124		
29	E9		61	00	For External Cal.	93	00	For External Cal.	125		
30	13	Tx Power Low Warming (-3dBm)	62	00	For External Cal.	94	00	For External Cal.	126		
31	94		63	00	For External Cal.	95		Check Sum	127		

Note: Address 128 – 247: customer R/W eeprom. Address 248 – 255: Vendor Specific.

Note: Specifications subject to change without notice.

REVISION HISTORY

Version	Subject	Release Date
1.0	Initial datasheet	2011/12/1
2.0	Revise package diagram	2013/7/1