

### SPS-8120G / SPS-8120BG

**(RoHS Compliant)**

### 3.3V / 1310 nm / 4.25 Gbps LC SFP SINGLE-MODE TRANSCEIVER

#### FEATURES

- Up to 4.25 Gbps Bi-directional Data Links
- Hot-Pluggable SFP Footprint LC Optical Transceiver
- Small Form-Factor Pluggable (SFP) MSA compatible
- Compliance with Fibre Channel FC-PI 400/200/100-SM-LC-L
- 1310 nm FP LD Transmitter
- AC/AC Coupling according to MSA
- Up to 10 km
- Single +3.3 V Power Supply
- RoHS Compliant
- 0 to 70°C Operating : SPS-8120G
- -10 to 85°C Operating : SPS-8120BG
- Class 1 Laser International Safety Standard IEC-60825 Compliant

#### APPLICATIONS

- Tri-rate 1.063/2.125/4.25 Gb/s Fibre Channel
- 1.25 Gb/s 1000 BASE-LX Ethernet

#### DESCRIPTION

The SPS-8120G series single mode transceiver is small form factor pluggable module for bi-directional serial optical data communications such as 4x/2x/1x Fibre Channel and 1000BASE Ethernet. It is with the SFP 20-pin connector to allow hot plug capability. This module is designed for single mode fiber and operates at a nominal wavelength of 1310 nm. The transmitter section uses a 1310 nm multiple quantum well DFB laser and is a class 1 laser compliant according to International Safety Standard IEC-60825. The receiver section uses an integrated InGaAs detector preamplifier (IDP) mounted in an optical header and a limiting post-amplifier IC.

#### LASER SAFETY

This single mode transceiver is a Class 1 laser product. It complies with IEC-60825 and FDA 21 CFR 1040.10 and 1040.11. The transceiver must be operated within the specified temperature and voltage limits. The optical ports of the module shall be terminated with an optical connector or with a dust plug.

#### ORDER INFORMATION

P/No.	Bit Rate (Gb/s)	FC-PI	Distance (km)	Wavelength (nm)	Package	Temp. (°C)	TX Power (dBm)	RX Sens. (dBm)	RoHS Compliant
SPS-8120G	4 / 2 / 1	400/200/100	20	1310 DFB	LC SFP	0 to 70	0 to -5	-18	Yes
SPS-8120BG	4 / 2 / 1	400/200/100	20	1310 DFB	LC SFP	-10 to 85	0 to -5	-18	Yes

#### Absolute Maximum Ratings

Parameter	Symbol	Min	Max	Units	Notes
Storage Temperature	Tstg	-40	85	°C	
Operating Case Temperature	Topr	0	70	°C	SPS-8120G
		-10	85		SPS-8120BG
Power Supply Voltage	Vcc	-0.5	3.6	V	

#### Recommended Operating Conditions

Parameter	Symbol	Min	Typ	Max	Units / Notes
Power Supply Voltage	Vcc	3.1	3.3	3.5	V
Operating Case Temperature	Topr	0		70	°C / SPS-8120G
		-10		85	°C / SPS-8120BG
Power Supply Current	I <sub>CC(TX+RX)</sub>		200	300	mA
Data Rate		1.0625		4.25	Gb/s

\*\*\*\*\*

### Transmitter Specifications (0°C < Topr < 70°C, 3.1V < Vcc < 3.5V)

Parameter	Symbol	Min	Typ	Max	Units	Notes
<b>Optical</b>						
Optical Transmit Power	Po	-5	---	0	dBm	1
Optical Modulation Amplitude@4.25Gb/s	OMA	500	---	---	μW	
Output Center Wavelength	λ	1260	1310	1360	nm	
Output Spectrum Width	Δλ	---		1	nm	-20 dB Width
Side Mode Suppression ratio	SMSR	30			dB	
Optical Rise / Fall Time (4.25Gb/s)	t <sub>r</sub> / t <sub>f</sub>			90	Ps	20 % to 80%,unfiltered
Relative Intensity Noise	RIN			-118	dB/Hz	
<b>Electrical</b>						
Data Input Current – Low	I <sub>IL</sub>	-350			μA	
Data Input Current – High	I <sub>IH</sub>			350	μA	
Differential Input Voltage	V <sub>IH</sub> - V <sub>IL</sub>	0.5		2.4	V	Peak-to-Peak
TX Disable Input Voltage – Low	T <sub>DIS, L</sub>	0		0.5	V	2
TX Disable Input Voltage – High	T <sub>DIS, H</sub>	2.0		Vcc	V	2
TX Disable Assert Time	T <sub>ASSERT</sub>			10	μs	
TX Disable Deassert Time	T <sub>DEASSERT</sub>			1	ms	
TX Fault Output Voltage -- Low	T <sub>FaultL</sub>	0		0.5	V	3
TX Fault Output Voltage -- High	T <sub>FaultH</sub>	2.0		Vcc+0.3	V	3

1. Output power is power coupled into a 9/125 μm single mode fiber.
2. There is an internal 4.7K to 10K ohm pull-up resistor to VccTX.
3. Open collector compatible, 4.7K to 10K ohm pull-up to Vcc (Host Supply Voltage).

### Receiver Specifications (0°C < Topr < 70°C, 3.1V < Vcc < 3.5V)

Parameter	Symbol	Min	Typ	Max	Units	Notes
<b>Optical</b>						
Sensitivity @4.25Gb/s	Sens1			29	μW	4
				-18	dBm	5
Sensitivity @2.125 / 1.063Gb/s	Sens2			15	μW	4
				-20	dBm	5
Maximum Input Power	Pin	0			dBm	
Signal Detect -- Asserted	Pa	---		-18	dBm	Transition: low to high
Signal Detect -- Deasserted	Pd	-30	---	---	dBm	Transition: high to low
Signal detect -- Hysteresis		1.0	---		dB	
Wavelength of Operation		1260	---	1600	Nm	
<b>Electrical</b>						
Differential Output Voltage	V <sub>OH</sub> - V <sub>OL</sub>	0.6		2.0	V	
Output LOS Voltage -- Low	V <sub>OL</sub>	0		0.5	V	6
Output LOS Voltage -- High	V <sub>OH</sub>	2.0		Vcc+0.3	V	6

4. Measured at PRBS 2<sup>7</sup>-1 at BER 1E-12.
5. Represents sensitivity based on OMA spec, as corrected to incoming Extinction Ratio of 9 dB. For example, an OMA of 29 μW is approximately equal to an average power of -17.3 dBm, average with an Extinction ratio of 9 dB.
6. Open collector compatible, 4.7K to 10K ohm pull-up to Vcc (Host Supply Voltage).

### CONNECTION DIAGRAM

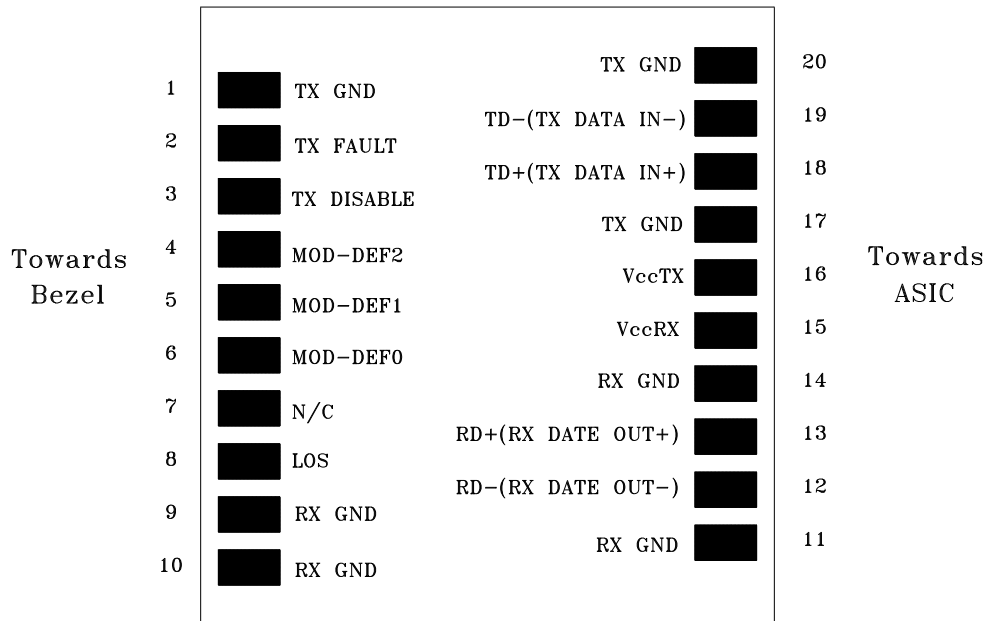

PIN	Signal Name	Description	PIN	Signal Name	Description
1	TX GND	Transmitter Ground	11	RX GND	Receiver Ground
2	TX Fault	Transmitter Fault Indication	12	RX DATA OUT-	Inverse Receiver Data Out
3	TX Disable	Transmitter Disable (Module disables on high or open)	13	RX DATA OUT+	Receiver Data Out
4	MOD-DFE2	Modulation Definition 2 – Two wires serial ID Interface	14	RX GND	Receiver Ground
5	MOD-DEF1	Modulation Definition 1 – Two wires serial ID Interface	15	Vcc RX	Receiver Power – 3.3V±5%
6	MOD-DEF0	Modulation Definition 0 – Ground in Module	16	Vcc TX	Transmitter Power – 3.3V±5%
7	N/C	Not Connected	17	TX GND	Transmitter Ground
8	LOS	Loss of Signal	18	TX DATA IN+	Transmitter Data In
9	RX GND	Receiver Ground	19	TX DATA IN-	Inverse Transmitter Data In
10	RX GND	Receiver Ground	20	TX GND	Transmitter Ground

### Module Definition

Module Definition	MOD-DEF2 PIN 4	MOD-DEF1 PIN 5	MOD-DEF0 PIN 6	Interpretation by Host
4	SDA	SCL	LV-TTL Low	Serial module definition protocol

Module Definition 4 specifies a serial definition protocol. For this definition, upon power up, MOD-DEF(1:2) appear as no connector (NC) and MOD-DEF(0) is TTL LOW. When the host system detects this condition, it activates the serial protocol. The protocol uses the 2-wire serial CMOS E<sup>2</sup>PROM protocol of the ATMEL AT24C01A/02/04 family of components.

### RECOMMENDED CIRCUIT SCHEMATIC

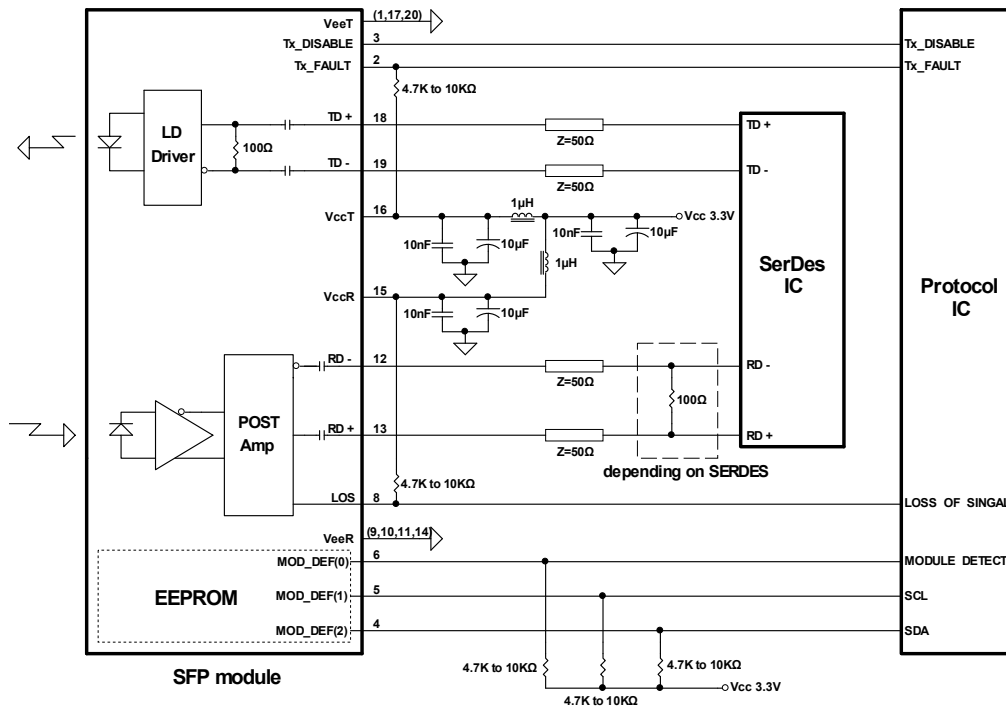

### PACKAGE DIAGRAM

Units in mm

Top View

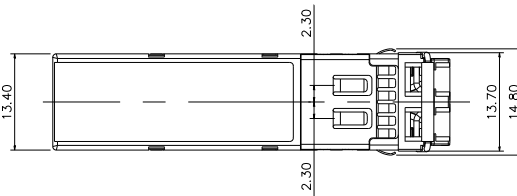

Front View

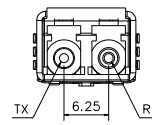
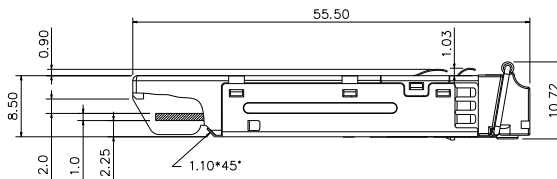

Side View

Bottom View

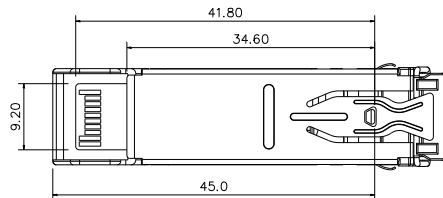

Note: Specifications subject to change without notice.

**Revision History**

Version	Subject	Release Date
1.0	Initial datasheet	2005/12/1
2.0	Revise package diagram for high port density use	2006/6/1