

SPS-9110FG / SPS-9110AFG

(RoHS Compliant)

3.3V / 1310 nm / 2.125 Gbps LC SFP SINGLE-MODE TRANSCEIVER

**FEATURES**

- Hot-Pluggable SFP Footprint LC Optical Transceiver
- Small Form-Factor Pluggable (SFP) MSA compatible
- Compliant with Fibre Channel 1X/2X SM-LC-L FC-PI
- Compliant with IEEE 802.3z 1000BASE-LX
- 1310 nm LD Transmitter
- Distance up to 10 km
- AC/AC Coupling according to MSA
- Single +3.3 V Power Supply
- RoHS Compliant
- -10 to 85°C Operation: SPS-9110FG
- -40 to 85°C Operation: SPS-9110AFG
- Class 1 Laser International Safety Standard IEC 60825 Compliant

**APPLICATIONS**

- ATM Switches and Routers
- SONET / SDH Switch Infrastructure
- XDSL Applications
- Metro Edge Switching

**DESCRIPTION**

The SPS-9110FG series single mode transceivers are small form factor pluggable module for bi-directional serial optical data communications such as Gigabit Ethernet 1000BASE-LX and Fibre Channel 1x/2x SM-LC-L FC-PI. It is with the SFP 20-pin connector to allow hot plug capability. This module is designed for single mode fiber and operates at a nominal wavelength of 1310 nm. The transmitter section uses a multiple quantum well laser and is a class 1 laser compliant according to International Safety Standard IEC-60825. The receiver section uses an integrated InGaAs detector preamplifier (IDP) mounted in an optical header and a limiting post-amplifier IC.

**LASER SAFETY**

This single mode transceiver is a Class 1 laser product. It complies with IEC 60825 and FDA 21 CFR 1040.10 and 1040.11. The transceiver must be operated within the specified temperature and voltage limits. The optical ports of the module shall be terminated with an optical connector or with a dust plug.

**ORDER INFORMATION**

P/No.	Bit Rate (Gb/s)	FC-PI	Distance (km)	Wavelength (nm)	Package	Temp. (°C)	TX Power (dBm)	RX Sens. (dBm)	RoHS Compliant
SPS-9110FG	2.125/1.063	200/100	10	1310	LC SFP	-10 to 85	-3 to -8	-21	Yes
SPS-9110AFG	2.125/1.063	200/100	10	1310	LC SFP	-40 to 85	-3 to -8	-21	Yes

**Absolute Maximum Ratings**

Parameter	Symbol	Min	Max	Units	Notes
Storage Temperature	Tstg	-40	85	°C	
Operating Case Temperature	Topr	-10 -40	85 85	°C	SPS-9110FG SPS-9110AFG
Power Supply Voltage	Vcc	-0.5	3.6	V	

**Recommended Operating Conditions**

Parameter	Symbol	Min	Typ	Max	Units / Notes
Power Supply Voltage	Vcc	3.1	3.3	3.5	V
Operating Case Temperature	Topr	-10 -40		85 85	°C / SPS-9110FG °C / SPS-9110AFG
Power Supply Current	I <sub>CC</sub> (TX+RX)		200	300	mA
Data Rate		1000	2125		Mb/s

Transmitter Specifications (-10°C < Topr < 85°C, 3.1V < Vcc < 3.5V)						
Parameter	Symbol	Min	Typ	Max	Units	Notes
<b>Optical</b>						
Optical Transmit Power	Po	-8	---	-3	dBm	1
Output Center Wavelength	$\lambda$	1270	1310	1350	nm	
Output Spectrum Width	$\Delta\lambda$	---	---	2.5	nm	RMS ( $\sigma$ )
Extinction Ratio	ER		9	---	dB	
Optical Modulation Amplitude (Peak-to-Peak)	OMA	174			$\mu$ W	FC-PI Standard
Optical Rise Time	t <sub>r</sub>			160	ps	20 % to 80% Values
Optical Fall Time	t <sub>f</sub>			160	ps	20 % to 80% Values
Relative Intensity Noise	RIN			-120	dB/Hz	
<b>Electrical</b>						
Data Input Current – Low	I <sub>IL</sub>	-350			$\mu$ A	
Data Input Current – High	I <sub>IH</sub>			350	$\mu$ A	
Differential Input Voltage	V <sub>IH</sub> - V <sub>IL</sub>	0.5		2.4	V	Peak-to-Peak
TX Disable Input Voltage – Low	T <sub>DIS,L</sub>	0		0.5	V	2
TX Disable Input Voltage – High	T <sub>DIS,H</sub>	2.0		Vcc	V	2
TX Disable Assert Time	T <sub>ASSERT</sub>			10	$\mu$ s	
TX Disable Deassert Time	T <sub>DEASSERT</sub>			1	ms	
TX Fault Output Voltage -- Low	T <sub>FaultL</sub>	0		0.8	V	3
TX Fault Output Voltage -- High	T <sub>FaultH</sub>	2.0		Vcc+0.3	V	3

1. Output power is power coupled into a 9/125  $\mu$ m single mode fiber.
2. There is an internal 4.7K to 10K ohm pull-up resistor to VccTX.
3. Open collector compatible, 4.7K to 10K ohm pull-up to Vcc (Host Supply Voltage).

Receiver Specifications (-10°C < Topr < 85°C, 3.1V < Vcc < 3.5V)						
Parameter	Symbol	Min	Typ	Max	Units	Notes
<b>Optical</b>						
Sensitivity @2.125Gb/s @ BER=10 <sup>-12</sup>	SENS (2X)	---	---	-21	dBm	4
Sensitivity @1.25Gb/s @ BER=10 <sup>-12</sup>	SENS (1X)			-22	dBm	4
Maximum Input Power	Pin	-3			dBm	4
Signal Detect -- Asserted	Pa	---		-21	dBm	Transition: low to high
Signal Detect -- Deasserted	Pd	-30	---	---	dBm	Transition: high to low
Signal detect -- Hysteresis		1.0	---		dB	
Wavelength of Operation		1100	---	1600	nm	
<b>Electrical</b>						
Differential Output Voltage	V <sub>OH</sub> - V <sub>OL</sub>	0.6		2.0	V	
Output LOS Voltage -- Low	V <sub>OL</sub>	0		0.8	V	5
Output LOS Voltage -- High	V <sub>OH</sub>	2.0		Vcc+0.3	V	5

4. Measured at 2<sup>7</sup>-1 PRBS at BER 1E-12 @ 1300 nm.
5. Open collector compatible, 4.7K to 10K ohm pull-up to Vcc (Host Supply Voltage).

\*\*\*\*\*  
**CONNECTION DIAGRAM**  
 \*\*\*\*\*

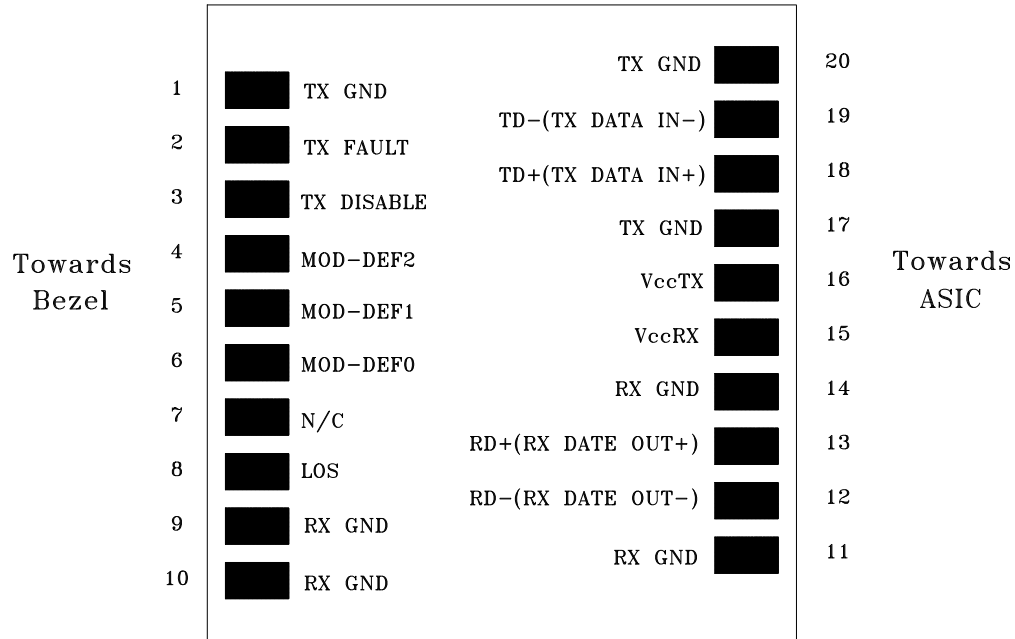

PIN	Signal Name	Description	PIN	Signal Name	Description
1	TX GND	Transmitter Ground	11	RX GND	Receiver Ground
2	TX Fault	Transmitter Fault Indication	12	RX DATA OUT-	Inverse Receiver Data Out
3	TX Disable	Transmitter Disable (Module disables on high or open)	13	RX DATA OUT+	Receiver Data Out
4	MOD-DFE2	Modulation Definition 2 – Two wires serial ID Interface	14	RX GND	Receiver Ground
5	MOD-DEF1	Modulation Definition 1 – Two wires serial ID Interface	15	Vcc RX	Receiver Power – 3.3V±5%
6	MOD-DEF0	Modulation Definition 0 – Ground in Module	16	Vcc TX	Transmitter Power – 3.3V±5%
7	N/C	Not Connected	17	TX GND	Transmitter Ground
8	LOS	Loss of Signal	18	TX DATA IN+	Transmitter Data In
9	RX GND	Receiver Ground	19	TX DATA IN-	Inverse Transmitter Data In
10	RX GND	Receiver Ground	20	TX GND	Transmitter Ground

**Module Definition**

Module Definition	MOD-DEF2 PIN 4	MOD-DEF1 PIN 5	MOD-DEF0 PIN 6	Interpretation by Host
4	SDA	SCL	LV-TTL Low	Serial module definition protocol

Module Definition 4 specifies a serial definition protocol. For this definition, upon power up, MOD-DEF(1:2) appear as no connector (NC) and MOD-DEF(0) is TTL LOW. When the host system detects this condition, it activates the serial protocol. The protocol uses the 2-wire serial CMOS E<sup>2</sup>PROM protocol of the ATMEL AT24C01A/02/04 family of components.

## RECOMMENDED CIRCUIT SCHEMATIC

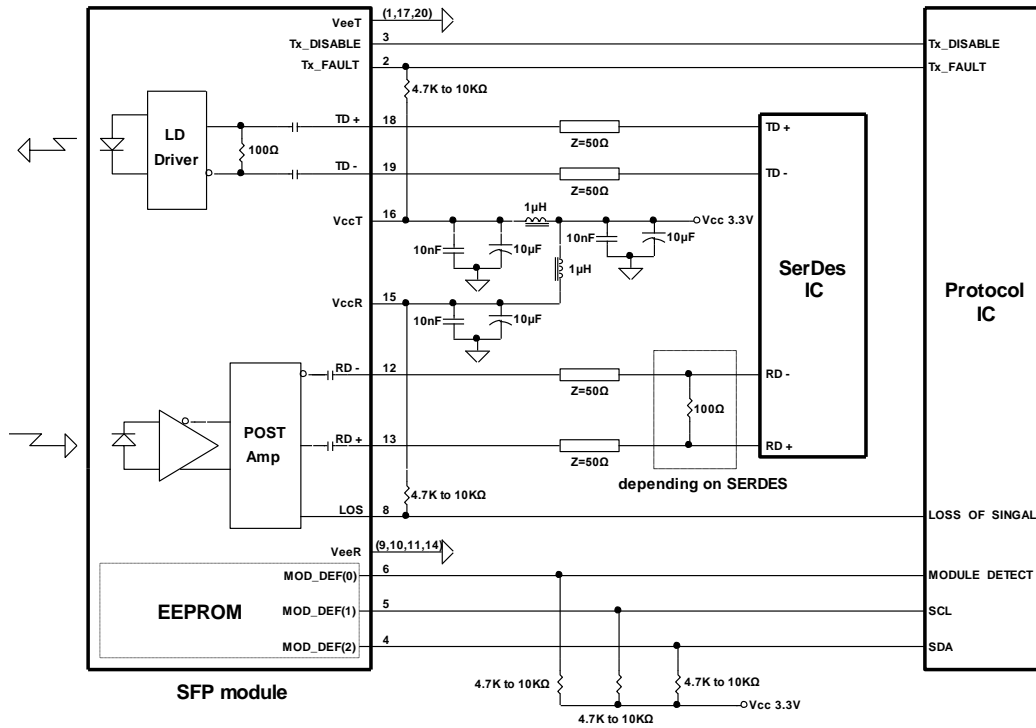

## PACKAGE DIAGRAM

Units in mm

Top View

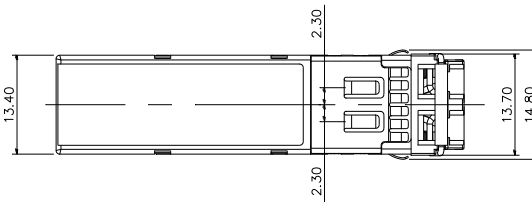

Front View

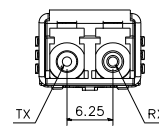
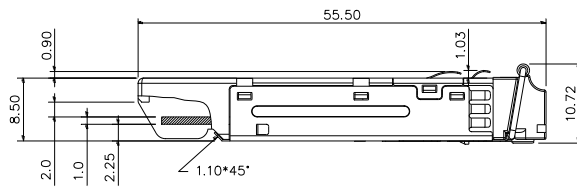

Side View

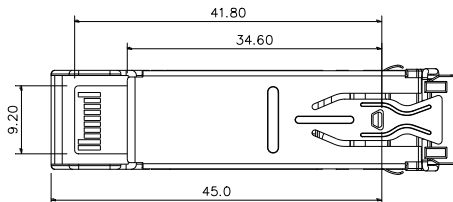

Bottom View

Note: Specifications subject to change without notice.

**Revision History**

<b>Version</b>	<b>Subject</b>	<b>Release Date</b>
1.0	Initial datasheet	2005/12/1
2.0	Revise package diagram for high port density use	2008/1/1