

SPS-93120VW-DXXG

(RoHS Compliant)

100GHz DWDM / 3Gb/s High Power SM Video Digital Diagnostic SFP Transceiver

FEATURES

- SMPTE 297-2006 Compatible
- Hot-Pluggable SFP Footprint LC Optical Transceiver
- Small Form-Factor Pluggable (SFP) MSA compatible
- Speed from 50 Mbps to 3 Gbps
- Distance up to 120 km for 3G-SDI
- Support Video Pathological Patterns for SD-SDI, HD-SDI and 3G-SDI
- SFF-8472 Digital Diagnostic Function
- Temperature-stabilized DWDM DML Transmitter
- 100 GHz ITU Grid, C Band
- 31 dB Power Budget at Least
- Single +3.3 V Power Supply
- RoHS Compliant
- 0 to 70°C Operation
- Class 1 Laser International Safety Standard IEC-60825 Compliant

APPLICATIONS

- SMPTE 297-2006 Compliant Electrical-to-Optical Interfaces
- High-density Video Routers

DESCRIPTION

The SPS-93120VW-DXXG is a single mode transceiver module designed to transmit/receive optical serial digital signals as defined in SMPTE 297-2006. It supports from 50 Mbps to 3 Gbps and is specifically designed for transmitted the SMPTE 259M, SMPTE 344M, SMPTE 292M and SMPTE 424M SDI pathological patterns. It is with the SFP 20-pin connector to allow hot plug capability. Digital diagnostic functions are available via an I²C. This module is designed for single mode fiber and operates at a nominal wavelength of 100GHz ITU Grid, C Band DWDM wavelength. A guaranteed minimum optical link budget of 31 dB is offered. The transmitter can transmit signal from 50 Mbps to 3 Gbps with up to 120 km of single-mode fiber. A maximum distance of 120 km is achievable with 3Gbps pathological signals.

LASER SAFETY

This single mode transceiver is a Class 1 laser product. It complies with IEC-60825 and FDA 21 CFR 1040.10 and 1040.11. The transceiver must be operated within the specified temperature and voltage limits. The optical ports of the module shall be terminated with an optical connector or with a dust plug.

ORDER INFORMATION

P/No.	Type	Bit Rate (Mb/s)	TX		RX		Package	Temp (°C)	RoHS Compliant
			λ (nm)	Power (dBm)	λ (nm)	Sen. (dBm)			
SPS-93120VW-DXXG	Transceiver	50 to 3000	DWDM*	7 to 3	1260/1620	-9 to -28	LC SFP with DMI	0 to 70	Yes

*XX: 100GHz ITU Grid wavelength (Please see below)

Channel #	Product code	Frequency (THz)	Center Wavelength (nm)	Label
20	SPS-93120VW-D20G	192.0	1561.42	D20
21	SPS-93120VW-D21G	192.1	1560.61	D21
22	SPS-93120VW-D22G	192.2	1559.79	D22
23	SPS-93120VW-D23G	192.3	1558.98	D23
24	SPS-93120VW-D24G	192.4	1558.17	D24
25	SPS-93120VW-D25G	192.5	1557.36	D25
26	SPS-93120VW-D26G	192.6	1556.55	D26
27	SPS-93120VW-D27G	192.7	1555.75	D27
28	SPS-93120VW-D28G	192.8	1554.94	D28
29	SPS-93120VW-D29G	192.9	1554.13	D29
30	SPS-93120VW-D30G	193.0	1553.33	D30
31	SPS-93120VW-D31G	193.1	1552.52	D31
32	SPS-93120VW-D32G	193.2	1551.72	D32
33	SPS-93120VW-D33G	193.3	1550.92	D33
34	SPS-93120VW-D34G	193.4	1550.12	D34
35	SPS-93120VW-D35G	193.5	1549.32	D35
36	SPS-93120VW-D36G	193.6	1548.51	D36
37	SPS-93120VW-D37G	193.7	1547.72	D37
38	SPS-93120VW-D38G	193.8	1546.92	D38
39	SPS-93120VW-D39G	193.9	1546.12	D39
40	SPS-93120VW-D40G	194.0	1545.32	D40
41	SPS-93120VW-D41G	194.1	1544.53	D41
42	SPS-93120VW-D42G	194.2	1543.73	D42
43	SPS-93120VW-D43G	194.3	1542.94	D43
44	SPS-93120VW-D44G	194.4	1542.14	D44
45	SPS-93120VW-D45G	194.5	1541.35	D45
46	SPS-93120VW-D46G	194.6	1540.56	D46
47	SPS-93120VW-D47G	194.7	1539.77	D47
48	SPS-93120VW-D48G	194.8	1538.98	D48
49	SPS-93120VW-D49G	194.9	1538.19	D49
50	SPS-93120VW-D50G	195.0	1537.40	D50
51	SPS-93120VW-D51G	195.1	1536.61	D51
52	SPS-93120VW-D52G	195.2	1535.82	D52
53	SPS-93120VW-D53G	195.3	1535.04	D53
54	SPS-93120VW-D54G	195.4	1534.25	D54
55	SPS-93120VW-D55G	195.5	1533.47	D55
56	SPS-93120VW-D56G	195.6	1532.68	D56
57	SPS-93120VW-D57G	195.7	1531.90	D57
58	SPS-93120VW-D58G	195.8	1531.12	D58
59	SPS-93120VW-D59G	195.9	1530.33	D59
60	SPS-93120VW-D60G	196.0	1529.55	D60

Absolute Maximum Ratings

Exposure to absolute maximum rating conditions for extended periods may affect device reliability.

Absolute Maximum Ratings					
Parameter	Symbol	Min	Max	Units	Notes
Storage Temperature	Tstg	-40	85	°C	
Operating Case Temperature	Topr	0	70	°C	
Power Supply Voltage	Vcc	0	4	V	
ESD Tolerance on all pins			1	KV	HBM
Relative Humidity	RH	5	95	% RH	Non-condensing

Recommended Operating Conditions					
Parameter	Symbol	Min	Typ	Max	Units / Notes
Power Supply Voltage	Vcc	3.13	3.3	3.47	V
Operating Case Temperature	Topr	0		70	°C
Data Rate		50		3000	Mb/s
Power Supply Current	I _{CC(TX+RX)}			430	mA

Transmitter Specifications (0°C < Tc < 70°C, 3.13V < Vcc < 3.47V)						
Parameter	Symbol	Min	Typ	Max	Units	Notes
Optical						
Average Launch Power	P _{O, AVG}	3	---	7	dBm	1
Center Wavelength Spacing			100		GHz	2
Transmitter Center Wavelength -- over life time	λ _c	X-100	X	X+100	pm	3
Output Spectrum Width	Δλ	---		1	nm	-20 dB width
Extinction Ratio	ER	5	7.5		dB	
Relative Intensity Noise	RIN			-120	dB/Hz	
Optical Rise Time / Fall Time	tr / tf			135	ps	4, SMPTE 424M
				270	ps	4, SMPTE 292M
				800	ps	4, SMPTE 344M
				1.5	ns	4, SMPTE 259M
Electrical						
Differential Input Voltage	V _{IH} - V _{IL}	200		800	mVp-p	AC coupled input
Disable Input Voltage -- Low	V _{TDIS,L}	0		0.8	V	TX Output Enabled
Disable Input Voltage -- High	V _{TDIS,H}	2.0		Vcc+0.3	V	TX Output Disabled
SCL, SDA	V _{OH}	2.5		Vcc+0.3	V	
	V _{OL}	0		0.5	V	

- Output power is power coupled into a 9/125 μm single mode fiber.
- Corresponds to approximately 0.8 nm.
- X = specified ITU Grid wavelength
- 20% to 80%, unfiltered.

Receiver Specifications (0°C < Tc < 70°C, 3.13V < Vcc < 3.47V)

Parameter	Symbol	Min	Typ	Max	Units	Notes
Optical						
Wavelength of Operation		1260	---	1620	nm	
Sensitivity for SMPTE 424M 2.97 Gb/s	Sen	-9	---	-28	dBm	Pathological
		-9		-28	dBm	PRBS 2 ²³ -1, BER=1E-12
Sensitivity for SMPTE 292M 1.485 Gb/s	Sen	-9	---	-28	dBm	Pathological
		-9		-28	dBm	PRBS 2 ²³ -1, BER=1E-12
Signal Detect -- Asserted	Pa	---	---	-28	dBm	Transition: low to high
Signal Detect -- Deasserted	Pd	-40	---	---	dBm	Transition: high to low
Signal detect -- Hysteresis		1		6	dB	
Optical Return Loss			-27		dB	
Electrical						
CML Output (Differential)		550	660	850	mVp-p	AC coupled output
Optical Rise Time / Fall Time	tr / tf			135	ps	5, SMPTE 424M
				270	ps	5, SMPTE 292M
				800	ps	5, SMPTE 344M
				1.5	ns	5, SMPTE 259M
Output LOS Voltage -- Low	V _{OL}	0		0.5	V	I _{OL} =-1.6mA, 1 TTL unit load
Output LOS Voltage -- High	V _{OH}	2.5		V _{CC} +0.3	V	I _{OH} =40μA, 1 TTL unit load
SCL, SDA	V _{OH}	2.5		V _{CC} +0.3	V	
	V _{OL}	0		0.5	V	

5. 20% to 80%, unfiltered.

CONNECTION DIAGRAM

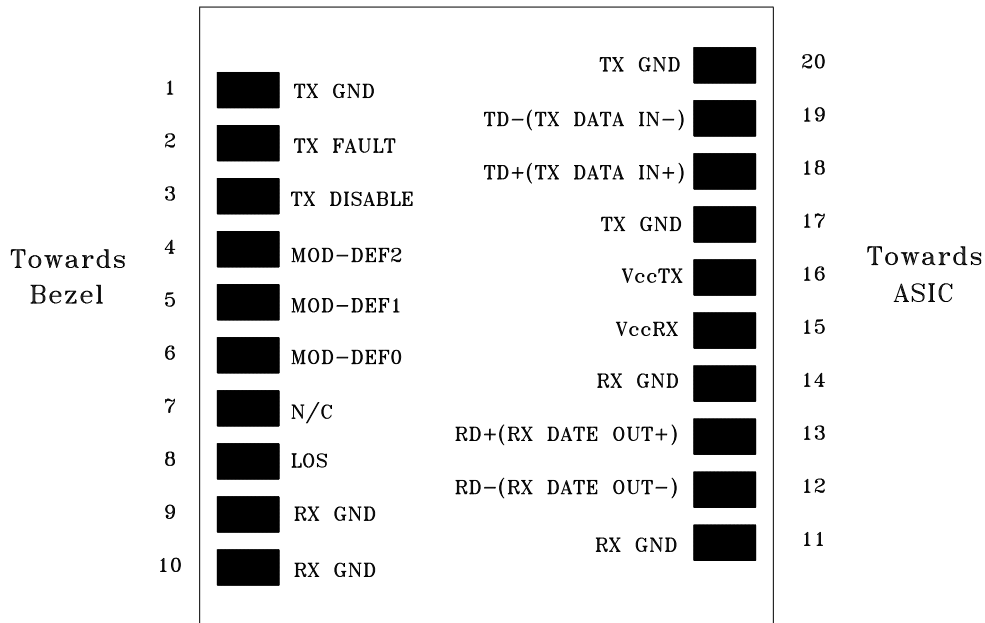

PIN	Signal Name	Description	PIN	Signal Name	Description
1	TX GND	Transmitter Ground	11	RX GND	Receiver Ground
2	TX Fault	Transmitter Fault Indication	12	RX DATA OUT-	Inverse Receiver Data Out
3	TX Disable	Transmitter Disable (Module disables on high or open)	13	RX DATA OUT+	Receiver Data Out
4	MOD-DFE2	Modulation Definition 2 – Two wires serial ID Interface	14	RX GND	Receiver Ground
5	MOD-DEF1	Modulation Definition 1 – Two wires serial ID Interface	15	Vcc RX	Receiver Power – 3.3V±5%
6	MOD-DEF0	Modulation Definition 0 – Ground in Module	16	Vcc TX	Transmitter Power – 3.3V±5%
7	N/C	Not Connected	17	TX GND	Transmitter Ground
8	LOS	Loss of Signal	18	TX DATA IN+	Transmitter Data In
9	RX GND	Receiver Ground	19	TX DATA IN-	Inverse Transmitter Data In
10	RX GND	Receiver Ground	20	TX GND	Transmitter Ground

Module Definition

Module Definition	MOD-DEF2 PIN 4	MOD-DEF1 PIN 5	MOD-DEF0 PIN 6	Interpretation by Host
4	SDA	SCL	LV-TTL Low	Serial module definition protocol

Module Definition 4 specifies a serial definition protocol. For this definition, upon power up, MOD-DEF(1:2) appear as no connector (NC) and MOD-DEF(0) is TTL LOW. When the host system detects this condition, it activates the serial protocol. The protocol uses the 2-wire serial CMOS E²PROM protocol of the ATMEL AT24C01A/02/04 family of components.

RECOMMENDED CIRCUIT SCHEMATIC

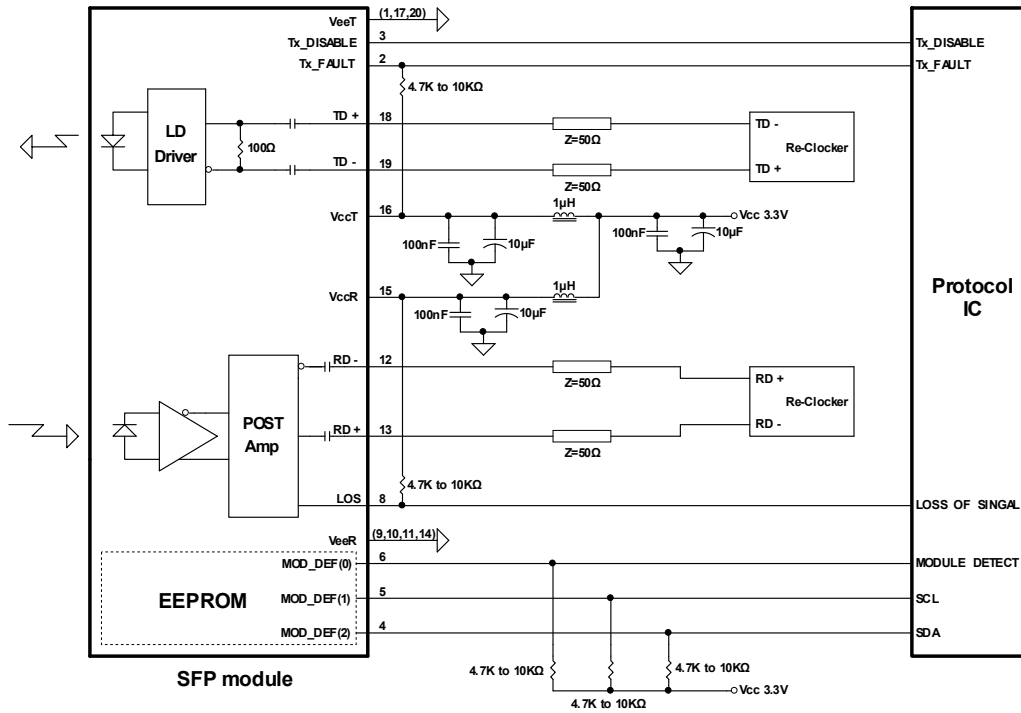

PACKAGE DIAGRAM

Units in mm

Top View

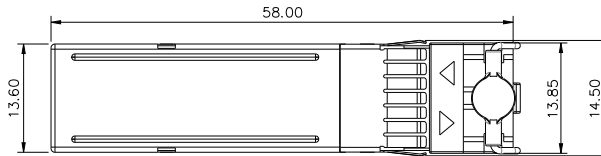

Front View

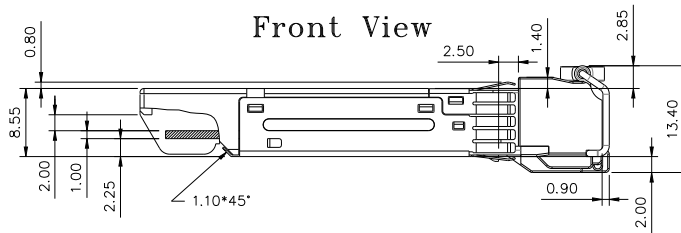

LATCH COLOR
White

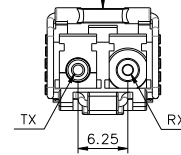

Side View

Bottom View

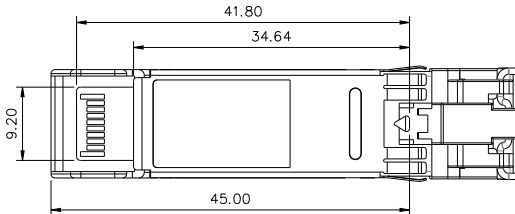

Note: Specifications subject to change without notice.

REVISION HISTORY

Version	Subject	Release Date
1.0	Initial datasheet	2017/4/5
