

TRML-8100G / TRML-8100BG / TRML-8100AG

(RoHS Compliant)

4.25 Gbps / 850 nm / 3.3V SFF LC MULTI-MODE TRANSCEIVER

FEATURES

- Up to 4.25 Gb/s Bi-directional Data Link
- Duplex LC Multi-Mode Transceiver
- Compliant with Fibre Channel FC-PH-2 for 400-M5-SN-1 and 400-M6-SN-1
- Compliant with IEEE 802.3z 1000BASE-SX
- Link Distance at 4.25 Gbd
 - 150 m links with 50/125 μ m MMF Cables
 - 70 m links with 62.5/125 μ m MMF Cables
- Link Distance at 2.125 Gbd
 - 300 links with 50/125 μ m MMF Cables
 - 150 m links with 62.5/125 μ m MMF Cables
- Link Distance at 1.063 Gbd
 - 500 m links with 50/125 μ m MMF Cables
 - 300 m links with 62.5/125 μ m MMF Cables
- Small Form Factor, RJ-45 size, 2X5 pin Package
- AC/AC Coupled Signal Input / Output
- LVTTTL Transmitter Disable Input
- LVTTTL Signal Detect Output
- Single +3.3 V Power Supply
- RoHS Compliant
- 0 to 70°C Operating: TRML-8100G
- -10 to 85°C Operating: TRML-8100BG
- -40 to 85°C Operating: TRML-8100AG
- Wave Solderable
- Class 1 Laser International Safety Standard IEC-60825 Compliant

APPLICATIONS

- Tri-Rate 4.25/2.125/1.063 Gb/s Fibre Channel
- 1.25 Gb/s 1000BASE-SX Ethernet

DESCRIPTION

The TRML-8100G series multi-mode transceiver is a small form factor, low power, high performance module for bi-directional serial optical data communications such as Fibre Channel 4x/2x/1x and Gigabit Ethernet 1000BASE-SX. This module is designed for multi-mode fiber and operates at a nominal wavelength of 850 nm. The transmitter section uses a multiple quantum well 850 nm VCSEL and is a class 1 laser compliant according to International Safety Standard IEC-60825. The receiver section uses an integrated GaAs detector preamplifier (IDP) mounted in an optical header and a limiting post-amplifier IC. A PECL logic interface simplifies interface to external circuitry.

LASER SAFETY

This multi-mode transceiver is a Class 1 laser product. It complies with IEC-60825 and FDA 21 CFR 1040.10 and 1040.11. The transceiver must be operated within the specified temperature and voltage limits. The optical ports of the module shall be terminated with an optical connector or with a dust plug.

ORDER INFORMATION

P/No.	Bit Rate (Gb/s)	FC	Distance (m)	Wavelength (nm)	Package	Temp. (°C)	TX Power (dBm)	RX Sens. (dBm)	RoHS Compliant
TRML-8100G	4 / 2 / 1	400/200/100	150/300/500	850	2X5 LC	0 to 70	-2.5 to -9	-15/-17/-18	Yes
TRML-8100BG	4 / 2 / 1	400/200/100	150/300/500	850	2X5 LC	-10 to 85	-2.5 to -9	-15/-17/-18	Yes
TRML-8100AG	4 / 2 / 1	400/200/100	150/300/500	850	2X5 LC	-40 to 85	-2.5 to -9	-15/-17/-18	Yes

Absolute Maximum Ratings					
Parameter	Symbol	Min	Max	Units	Notes
Storage Temperature	Tstg	-40	85	°C	
Operating Temperature	Topr	0	70	°C	TRML-8100G
		-10	85		TRML-8100BG
		-40	85		TRML-8100AG
Soldering Temperature	---		260	°C	10 seconds on leads only
Power Supply Voltage	Vcc	0	4.5	V	
Input Voltage	---	GND	Vcc	V	

Recommended Operating Conditions					
Parameter	Symbol	Min	Typ	Max	Units / Notes
Power Supply Voltage	Vcc	3.13	3.3	3.47	V
Operating Temperature	Topr	0 -10 -40		70 85 85	°C / TRML-8100G °C / TRML-8100BG °C / TRML-8100AG
Data Rate		1062	4250		Mb/s
Power Supply Current	Icc		180	240	mA

Transmitter Specifications (0°C < Topr < 70°C, 3.13V < Vcc < 3.47V)						
Parameter	Symbol	Min	Typ	Max	Units	Notes
Optical						
Optical Transmit Power	Po	-9	---	-2.5	dBm	1
Output Center Wavelength	λ	840	850	860	nm	
Output Spectrum Width	$\Delta\lambda$	---	---	0.85	nm	RMS (σ)
Optical Modulation Amplitude@4.25Gb/s	OMA	247			μ W	2
Optical Modulation Amplitude@2.125Gb/s	OMA	196			μ W	
Optical Modulation Amplitude@1.063Gb/s	OMA	156			μ W	
Optical Rise Time	t_r			90	ps	20% to 80%
Optical Fall Time	t_f			90	ps	20% to 80%
Relative Intensity Noise	RIN			-118	dB/Hz	
Electrical						
Data Input Current – Low	I _{IL}	-350			μ A	
Data Input Current – High	I _{IH}			350	μ A	
Differential Input Voltage	V _{IH} - V _{IL}	300			mV	
Data Input Voltage – Low	V _{IL} - V _{CC}	-2.0		-1.58	V	3
Data Input Voltage -- High	V _{IH} - V _{CC}	-1.1		-0.74	V	3
Disable Input Voltage -- Low	V _{TDIS,L}	0		0.5	V	TX Output Enabled
Disable Input Voltage -- High	V _{TDIS,H}	Vcc – 1.3		Vcc	V	TX Output Disabled
Shut Off Time for TxDis	t _{DIS}			1	ms	

- Notes: 1. Output power is power coupled into a 62.5/125 μ m MM fiber.
 2. An OMA of 196 μ W is approximately equal to an average power of -9 dBm assuming an Extinction Ratio of 9 dB.
 3. These inputs are compatible with 10K, 10KH and 100K ECL and PECL inputs.

Receiver Specifications (0°C < Topr < 70°C, 3.13V < Vcc < 3.47V)						
Parameter	Symbol	Min	Typ	Max	Units	Notes
Optical						
Sensitivity@4.25Gb/s	Sens			-15 40	dBm μW	4
Sensitivity@2.125Gb/s	Sens			-17	dBm	4
Sensitivity@1.063Gb/s	Sens			-18	dBm	4
Maximum Input Power	Pin	0		---	dBm	
Signal Detect – Asserted	Pa	---	---	-18	dBm	Transition: low to high
Signal Detect – Deasserted	Pd	-31	---	---	dBm	Transition: high to low
Signal detect – Hysteresis		1.0	---		dB	
Wavelength of Operation		830	---	860	nm	
Electrical						
Data Output Voltage – Low	V _{OL} - V _{CC}	-2.0		-1.58	V	5
Data Output Voltage – High	V _{OH} - V _{CC}	-1.1		-0.74	V	5
Signal Detect Output Voltage -- Low	V _{OL}			0.5	V	
Signal Detect Output Voltage -- High	V _{OH}	2.0			V	

Notes: 4. Minimum sensitivity and saturation levels at BER=1E-12 for a 2⁷-1 PRBS.
 5. These outputs are compatible with 10K, 10KH and 100K ECL and PECL outputs.

CONNECTION DIAGRAM

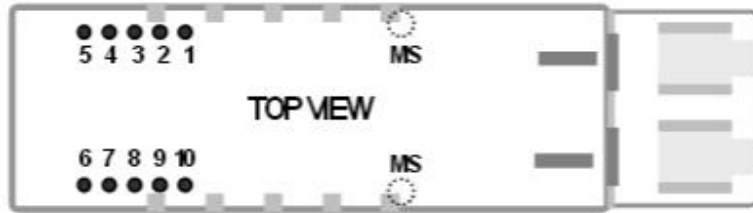

PIN	Symbol	Notes
1	V _{EE} RX	Directly connect this pin to the receiver ground plane
2	V _{CC} RX	+3.3V dc power for the receiver section
3	SD	Active high on this indicates a received optical signal.
4	RD-	Receiver Dataout Bar. See recommended circuit schematic
5	RD+	Receiver Dataout. See recommended circuit schematic
6	V _{CC} TX	+3.3V dc power for the transmitter section
7	V _{EE} TX	Directly connect this pin to the transmitter ground plane
8	TX_Disable	Transmitter Disable. Connect this pin to +3.3V TTL logic "1" to disable module To enable module connect to TTL logic low "0"
9	TD+	Transmitter Data In. See recommended circuit schematic
10	TD-	Transmitter Data In Bar. See recommended circuit schematic
MS	MS	Mounting Studs. Connect to Chassis Ground

RECOMMENDED CIRCUIT SCHEMATIC

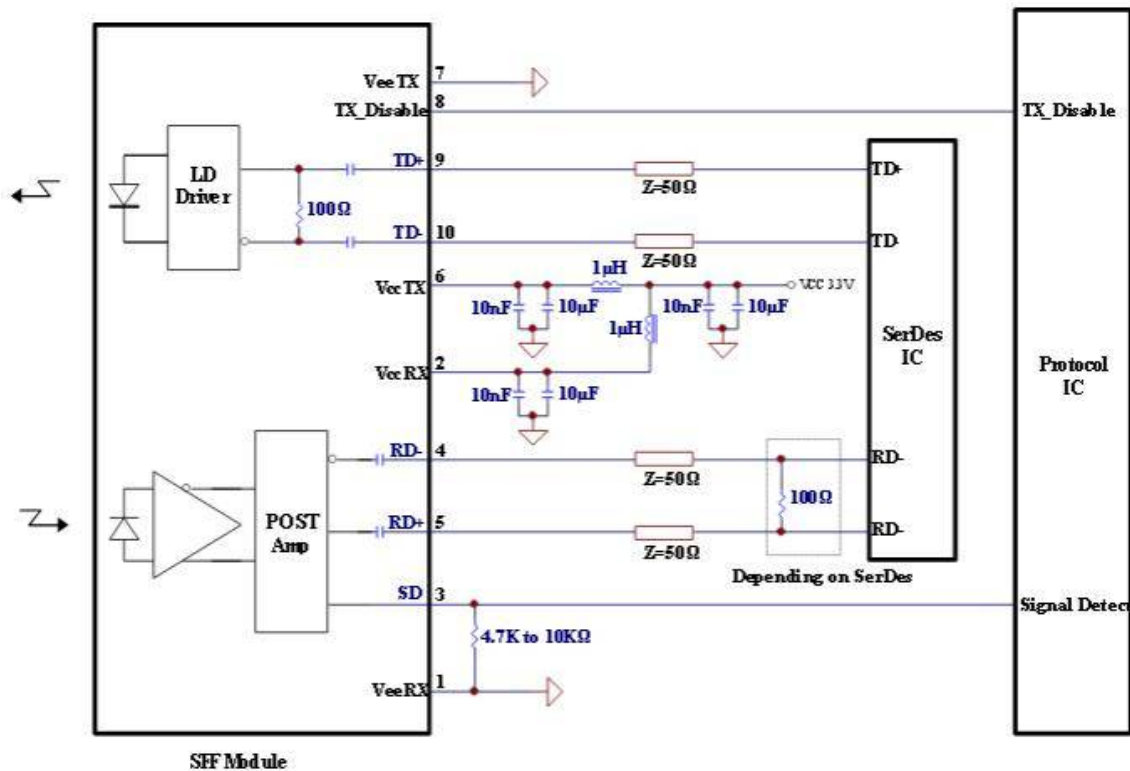

PACKAGE DIAGRAM (Units in mm)

A) Standard Case

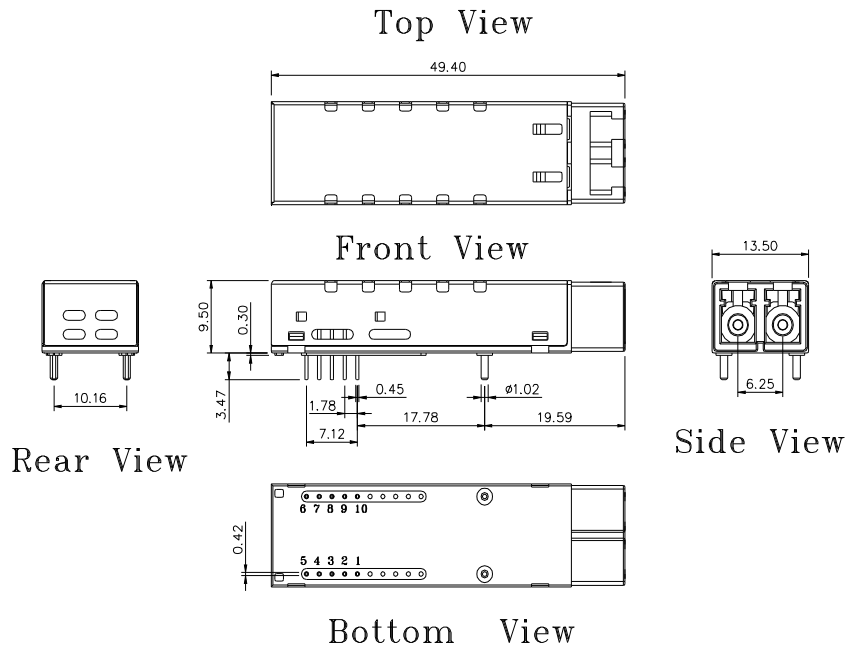

TRML-8100G / TRML-8100BG

B) Extended Case

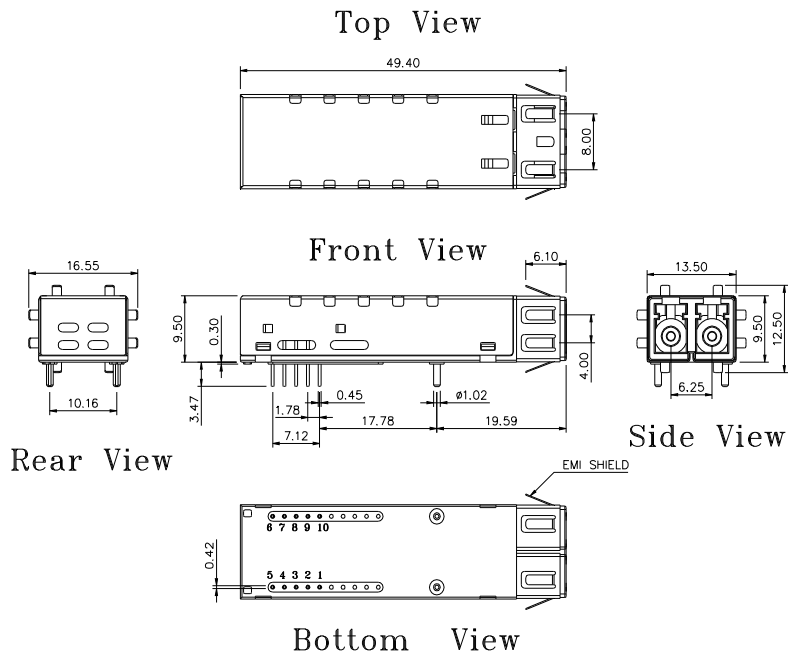

TRML-8100EG / TRML-8100BEG

Note: Specifications subject to change without notice.

REVISION HISTORY

Version	Subject	Release Date
1.0	Initial datasheet	2007/04/01